



**City of Wilmington
1165 South Water Street
Wilmington, IL 60481**

**Agenda
Regular City Council Meeting
Wilmington City Hall
Council Chambers
August 21, 2018
7:00 p.m.**

I. Call to Order

II. Pledge of Allegiance

III. Roll Call by City Clerk	John Persic, Jr.	Kevin Kirwin
	Dennis Vice	Floyd Combes
	Lisa Butler	Fran Tutor
	Steve Evans	Frank Studer

IV. Approval of Minutes from the August 7, 2018 Regular City Council Meeting

V. Mayor's Report

1. Mayoral Appointment of Bryan Humphries to the Wilmington Police Pension Board – 3-year term (August 2018 – August 2021)
2. Mayoral Appointment of Dave Schultz to the Wilmington Police Pension Board – 2-year term (August 2018 – August 2020)

VI. Public Comment

(State your full name clearly; limit 5 minutes each per Ordinance 17-10-17-05)

VII. Planning & Zoning Commission

1. Approve Ordinance No. 18-08-21-01, An Ordinance Adopting the Downtown Plan for the City of Wilmington, Will County, Illinois
2. The next scheduled meeting is Thursday, September 6, 2018 at 5:00 p.m.

*Posting Date:
8/17/2018 2:24 PM hh*

VIII. Committee Reports

A. Buildings, Grounds, Parks, Health & Safety Committee

Co-Chairs – John Persic, Jr. & Steve Evans

1. Approve the Proposal submitted by Uni-Max Management Corp, for professional cleaning services at Wilmington City Hall and Wilmington Police Department
2. The next scheduled meeting is Wednesday, September 12, 2018 at 5:30 p.m.

B. Water, Sewer, Streets & Alleys Committee

Co-Chairs – Frank Studer & Kevin Kirwin

1. The next scheduled meeting is Wednesday, September 12, 2018 at 6:00 p.m.

C. Police & ESDA Committee

Co-Chairs – Frank Studer & Fran Tutor

1. Approve Intergovernmental Agreement between the County of Will and City of Wilmington
2. The next scheduled meeting is Tuesday, September 11, 2018 at 5:30 p.m.

D. Finance, Administration & Land Acquisition Committee

Co-Chairs – Frank Studer & Fran Tutor

1. Approve the Accounting Reports are Presented by the City Account
2. Approve ESI Supplement for Construction Services for South Arsenal Road at IL 53
3. Approve ESI Proposal for Supplemental Professional Engineering for Phased Construction of Intersection Improvement-Stage 2 for South Arsenal Road at IL 53
4. Approve ESI Proposal for Construction Services for Peotone Road at IL 53
5. Approve ESI Proposal for Supplemental Professional Engineering Services for Modifications Related to Historic Route 66 at N. River Road at IL 53

6. Approve Equipment Purchases for the Public Work Department
7. The next scheduled meeting is Tuesday, September 18, 2018 at 6:00 p.m.

E. Ordinance & License Committee
Co-Chairs – Lisa Butler & Floyd Combes

1. Approve Ordinance No. 18-08-21-02, An Ordinance Regulating Food Truck Permits within The City of Wilmington
2. The next scheduled meeting is Tuesday, September 11, 2018 at 6:00 p.m.

F. Personnel & Collective Bargaining Committee
Co-Chairs – John Persic, Jr. & Dennis Vice

1. Approve and Authorize the Public Works Director to seek and hire One Permanent Full-Time Employee for the Public Works Department at the Street Crew 1 Laborer Position

IX. Attorney's Report

X. Executive Session

1. Appointment, Employment, Compensation, Discipline, Performance or Dismissal of Specific Employees [5 ILCS 120/2(c)(1)]
2. Collective Negotiating Matters [5 ILCS 120/2(c)(2)]
3. Matters of Land Acquisition [2(c)(5) and 2(c)(6)]

XI. Action to be taken at the next Executive Session

XII. Adjournment

The next City Council meeting is Tuesday, September 4, 2018 at 7:00 p.m.

Draft

**Minutes of the Regular Meeting of the
Wilmington City Council**
Wilmington City Hall
1165 South Water Street
Tuesday, August 7, 2018

Call to Order

The Regular Meeting of the Wilmington City Council on August 7, 2018 was called to order at 7:02 p.m. by Mayor Roy Strong in the Council Chambers of the Wilmington City Hall.

Roll Call

Upon Roll Call by the Clerk the following members of the corporate authorities answered “Here” or “Present”:

Aldermen Present Studer, Tutor, Persic, Butler, Kirwin, Vice, Evans, Combes

Quorum

There being a sufficient number of members of the corporate authorities in attendance to constitute a quorum, the meeting was declared in order.

Other Officials in Attendance

Also, in attendance were the Deputy City Clerk Joie Ziller and Attorney Bryan Wellner

Approval of Minutes

Alderman Tutor made a motion and Alderman Combes seconded to approve the July 17, 2018 Regular City Council meeting minutes and have them placed on file

Upon roll call, the vote was:

AYES: 8 Evans, Tutor, Kirwin, Vice, Butler, Combes, Persic, Studer

NAYS: 0

The motion carried.

Open Public Hearing

Maggie Dar, Planner with Chicago’s Metropolitan Agency for Planning, CMAP, provides a broad overview of the Wilmington Downtown Plan that CMAP has developed with the City. She provides a background on her agency and how the project came about: CMAP is the regional planning agency, who was established by the State in 2005 to coordinate land use and transportation issues within the 7 county regions. They developed the first company as a regional plan called GoTo 2040 and since the Board adopted that plan in 2010 they have been implementing it by narrowing thru the local technical systems work. So it is thru that program that they are able to provide direct planning assistance work to communities throughout the region. They have an annual call for projects and since 2011 they have completed over 100 projects in the region and have about 50 currently under way. The City of Wilmington sought technical assistance from our LTA program back in 2015, and the City had requested assistance in the development of a Corridor Plan at that time, so looking at 53 and 102. The project was accepted and they determined that a downtown plan might be more appropriate as it would allow

Draft

them to focus more narrowly on economic development issues, not just transportation but the economy, walk ability, natural resources, it would allow them to take a deeper dive into the downtown area. The purpose of this project has been to present a unified vision for the downtown and second to identify strategies to support economic growth, increase safety and connectivity and engage local and regional partners in implementation of priority projects. The plan document itself is available online. It is to serve as a guidebook for people who will be making decisions about development or redevelopment that affects the downtown. The process includes multiple steps that kicked off in late 2016. They worked closely with the City to develop a scope of work. They released an interim deliverable called existing conditions reports which was released last July. This was really the document where they outlined what they had heard about the key different assets in the downtown, issues and opportunities, things to be addressed in the downtown plan. Now they are on to public review of the document and into the adoption process. There is a public open house in June where they had a really great turnout in the park district, and got some great positive feedback. The Plan is organized into 8 chapters. After the introduction there is a chapter titled "Vision For Downtown Wilmington", which really summarizes the results of that public workshop. An overview of some of the projects are: Evaluate the Potential for River walk along the Millrace: They heard from many stakeholders that there was a strong vision to establish a unique pedestrian riverfront experience, connecting North Water Street with the Kankakee river. Concept Illustrations: illustrates some of the ideas that came up, boardwalk style walking path, gardens, kayak dock and an overlook deck. The plan also highlights some sights that should be prioritized for redevelopment including hotel, launching pad, properties owned by the fire protection district and the north portion of Water Street. There are a lot of great ideas that need a dedicated funding source to support those efforts. The Plan is recommending that the City evaluate establishing a business district. Transportation Chapter: One of the primary recommendations is to strengthen local bicycle facilities. So since traveling along the main corridors isn't a viable option because of the narrow right of ways as well as the heavy truck traffic, we are showing the plan a way to support a local bikeway network along other roadways, instead of 53, we are looking at Jackson Street. The safety issues at the Wilmington Dam came up again and again. It is included as a priority in the plan. Each stakeholder really wanted to see this addressed. The plan is an advocate for one scenario over another. What we tried to do is include as much information as possible about what those options look like, highlighting case studies from throughout the region. Once the plan is adopted is when the work begins. A short-term work plan that highlights what should be done first. CMAP will remain involved after the plan is adopted. Their assistance takes many forms. Identifying and supporting grant applications. They realize that funding is a major component of any local planning project. They have a group that meets every two weeks to discuss what new funding opportunities and grants are open. They are also here to facilitate operations with regional and state facilities. CMAP has all kinds of contacts and are willing to set up meetings. The Mayor states that they started working on the increase of sales tax to help the downtown area. The City used to have a matching program but it is gone now, three people took advantage of it. They are spending a lot of money downtown now. Another group is coming in for property. The Eagle Hotel is always looking for investors. Looking for money to take some trees out at the point. The dam is a nightmare and hopefully something would be done there. There was a drowning on Memorial Day, so now there is no bank fishing. A couple groups downtown have approached the City to try and help improve the downtown. Mike Mikolowski speaks up and asks Maggie if they have any plans for the South Side of downtown. She says that CMAP expands a wide range of downtown on 53.

Close Public Hearing at 7:25 p.m.

Upon roll call, the vote was:

AYES: 8 Evans, Tutor, Kirwin, Vice, Butler, Combes, Persic, Studer

NAYS: 0

The motion carried.

Mayor's Report

Mayor Strong announces Residential Electronics & Hazardous Waste Drop-off Event, Saturday, September 15, 2018 from 8 a.m. to 3 p.m.

Catfish Day's was the best Catfish Days we have ever had. Broke a lot of records. Tuffy's did the best he ever had. Rustic did the best ever on Thursday night. Nice weather, nice parade. Next year July 4, Thursday, if we extend that as a long weekend before or after that Thursday for the fireworks.

National Night Out is tonight at the High School until 8:30.

Public Comment

Roy Kenneth for the VFW Post 5422 states his Post was destroyed by fire on April 2016 and claims against the insurance have been in the courts since then. The court claims are now coming to a close with the insurance company; they are not up to date but will be in court this upcoming week. The VFW has always been a service to the community, offering aid to Veterans in need amounting up to thousands of dollars. Additionally the VFW offered \$1,000 in scholarships to seven students annually. The VFW Honor Guard, work at the Abraham Lincoln Cemetery providing funeral honor for Veterans on a weekly basis. They also provide off site dinners in May and November for Veterans from Dwight, Manteno, LaSalle, and a couple other areas. The VFW is requesting a building permit for Non for profit organization; they are requesting that this be at no charge. At this time they have secured an Architect, Engineer, Foundation, Plumbers, and electricians, heating and cooling. They are currently waiting for the City to allow them the permit and the rest of the funds to come from the court. The Mayor states that there should be no problem waiving the Permit Fee. He also states that they will need a bigger water line tap. Accurate Plan Review the VFW's plans for the City and the VFW will incur the costs. The VFW will be going from 5,000 to 10,000 feet larger. The building will take 3 weeks to be built once they receive the money.

Planning & Zoning Commission

Alderman Evans made a motion and Alderman Persic seconded to approve Ordinance No. 18-08-07-01, Authorizing a Variance to Allow For the Placement of Accessory Structure to be Built in Front of Home on Lot 2 in Kankakee River Ridge Subdivision Located on West River Road, Wilmington, Illinois

The next meeting is scheduled for Thursday, September 6, 2018 at 5:00 p.m.

Draft

Committee Reports

Buildings, Grounds, Parks, Health & Safety Committee

The next scheduled meeting is Wednesday, August 15, 2018 at 5:30 p.m.

Water, Sewer, Streets and Alleys Committee

The next scheduled meeting is Wednesday, August 15, 2018 at 6:00 p.m.

Police & ESDA Committee

The next scheduled meeting is Tuesday, August 14, 2018 at 5:30 p.m.

Finance, Administration & Land Acquisition Committee

Alderman Tutor made a motion and Alderman Butler seconded to approve the Accounts Payable Report dated August 7, 2018 in the amount of \$ 2,642,892.54, as presented by the City Accountant

Upon roll call, the vote was:

AYES: 8 Studer, Persic, Evans, Tutor, Kirwin, Vice, Butler, Combes

NAYS: 0

The motion carried.

The next scheduled meeting is Tuesday, August 21, 2018 at 6:00 p.m.

Ordinance & License Committee

Co-Chairs – Floyd Combes & Lisa Butler

Alderman Butler made a motion and Alderman Kirwin seconded to approve Ordinance No. 18-08-07-02, An Ordinance to Dissolve and Repeal the Economic Development Commission.

Upon roll call, the vote was:

AYES: 8 Studer, Persic, Evans, Tutor, Kirwin, Vice, Butler, Combes

NAYS: 0

The motion carried.

The next scheduled meeting is Tuesday, August 14, 2018 at 6:00 p.m.

Personnel & Collective Bargaining Committee

Co-Chairs – John Persic Jr.

Nothing at this time

Attorney's Report

Nothing at this time

Action Taken Following Executive Session

Nothing at this time.

Adjournment

Motion to adjourn the meeting made by Alderman Tutor and seconded by Alderman Kirwin.

Upon voice vote, the motion carried. The Regular Meeting of the City of Wilmington City Council held on August 7, 2018 adjourned at 7:37 p.m.

Respectfully submitted,

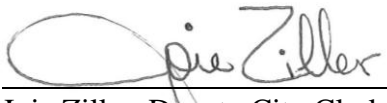

Joie Ziller, Deputy City Clerk

ORDINANCE NO. 18-08-21-01

AN ORDINANCE ADOPTING THE DOWNTOWN PLAN FOR THE CITY OF WILMINGTON, WILL COUNTY, ILLINOIS

WHEREAS, the City of Wilmington is an Illinois Municipal Corporation; and

WHEREAS, the Chicago Metropolitan Agency for Planning (herein after referred to as “CMAP”) is an established as a political subdivision, body politic, and municipal corporation created under Public Act 095-0677 to provide and address the development of public and private investments in the northeastern Illinois region; and

WHEREAS, CMAP created a Downtown Plan for the City of Wilmington, attached hereto as Exhibit A; and

WHEREAS, CMAP held a public open house event, public visioning workshop, conducted an online survey, and held other events to collect information and gather data from residents and business owners within the City of Wilmington to assist in creating the downtown plan; and

WHEREAS, on August 7, 2018, Wilmington City Council held a public hearing at Wilmington City Hall after publishing a public notice provided by law; and

WHEREAS, at the public hearing, CMAP presented its Downtown Plan, answered questions from the public and City Councilmembers, and the public had an opportunity to provide its own comments on the Downtown Plan; and

WHEREAS, there were no objectors to CMAP’s Downtown Plan;

WHEREAS, the City of Wilmington City Council determines it is in the best interest of the City of Wilmington, its residents, and its businesses to adopt and publish A Downtown Plan for the City of Wilmington, as attached hereto as Exhibit A, as the comprehensive downtown development plan for the City of Wilmington.

NOW THEREFORE, BE IT ORDAINED BY THE MAYOR AND CITY OF COUNCIL OF THE CITY OF WILMINGTON, WILL COUNTY, ILLINOIS, AS FOLLOWS:

Section 1: Adoption of A Downtown Plan for the City of Wilmington

A Downtown Plan for the City of Wilmington, attached hereto marked as Exhibit “A,” is hereby adopted as the comprehensive downtown development plan for the City of Wilmington, Illinois.

Section 2: Repealer

All Ordinances or parts of Ordinances in conflict with any of the provisions of this Ordinance shall be, and the same are hereby repealed.

Section 3: Severability

This Ordinance and every provision thereof, shall be considered severable. In the event that any court of competent jurisdiction may find and declare any word, phrase, clause, sentence, paragraph, provision or section or part of a phrase, clause, sentence, paragraph, provision or section of this Ordinance is void or unconstitutional, the remaining words, phrases, clauses, sentences, paragraphs, provisions and sections not ruled void or unconstitutional shall continue in full force and effect.

Section 4: Effective Date

This Ordinance shall be in full force and effect from and after its passage, approval and publication as provided by law.

PASSED this 21st day of August, 2018 with _____ members voting aye, _____ members voting nay, the Mayor voting _____, with _____ members abstaining or passing and said vote being:

John Persic, Jr.	_____	Kevin Kirwin	_____
Dennis Vice	_____	Floyd Combes	_____
Fran Tutor	_____	Lisa Butler	_____
Steve Evans	_____	Frank Studer	_____

Approved this 21st day of August, 2018

Roy Strong, Mayor

Attest:

Joie Ziller, Deputy City Clerk

COST PROPOSAL/EXECUTION OF PROPOSAL:

By submitting this proposal, the potential Contractor certifies the following:

This proposal is signed by an authorized representative of the firm.

The Contractor can obtain insurance certificates as required within 10 calendar days after notice of award.

The cost and availability of all equipment, materials, and supplies associated with performing the services described herein have been determined and included in the proposed cost.

All labor costs, direct and indirect, have been determined and included in the proposed cost.

The Contractor is aware of prevailing conditions associated with performing these services.

The potential Contractor has read and understands the conditions set forth in this RFP and agrees to them with no exceptions. If exceptions exist, they must be listed on a separate numbered sheet.

Therefore, in compliance with this Request for Proposals, and subject to all conditions herein, the undersigned offers and agrees to perform the services in accordance with the specifications and conditions in this RFP at the prices quoted, if this proposal is accepted within 60 days from the date of the opening.

Contractor: UNI MAX MANAGEMENT CORP

Address: 5854 N NORTHWEST HWY

City, State, Zip: CHICAGO, IL 60631

Telephone: 773-858-2276 Fax: 815-905-0009

Email: EVA.AMBROZBYA100.COM

By: 
Signature

EVA AMBROZ
Printed Name

ACCOUNT EXECUTIVE
Title

8-13-18
Date

Proposal Form
Request for Proposals for Cleaning Services

The following proposal for monthly cost of cleaning services for the City of Wilmington buildings as submitted by:

Name of Contractor: UNI MAX MANAGEMENT CORP

City Hall, 1165 S. Water Street \$ 700.00

Wilmington Police Department, 129 Robert P. Weidling Drive \$ 1250.00

Monthly Total: \$ 1,950.00

Worker's Compensation Certification

I hereby certify that effective the date of my Contract with the City of Wilmington and at all times in the performance of such Contract that:

I have and will maintain in full force and effect the Workers Compensation Insurance in compliance with the laws of the State of Illinois, and will provide a Certificate of Insurance to the City upon request, with the following insurance company:

HARTFORD

Company Name

Collette Celaya 4 Westbrook Corp Center # 500 Westchester, 71
Agent's Name, Address, and Telephone Number 847-745-1764

83 WEC Px 4548

2/3/2019

Policy Number and Effective Date

OR

I will perform said Contract myself and do not have and will not have any employee or employees assisting me with the performance of the Contract and am not required by the Laws of the State of Illinois to obtain and maintain a Worker's Compensation Insurance in the performance of this Contract.

I understand that this statement is made as a material part of the Contract, which I have, or will execute, with the City of Wilmington.

8-13-18

Date



Signature of Contractor

PRIME CONTRACTOR'S CERTIFICATION

I, EVA AMBROZ, an Authorized Officer or Agent for
(Print Name of Authorized Officer or Agent)

EVA AMBROZ, which is the Prime Contractor for
(Print Name of Prime Contractor)

UNIMAX MANAGEMENT CO, INC
(Name or Description of Contracted)

do hereby certify under oath that said Prime Contractor is not barred from contracting with any unit of State or local government as a result of a violation of either §33E-3 (Bid Rigging) or 33E-4 (Bid Rotating) of 720 ILCS 5/ Criminal Code of 2012. **NOTE: A person who makes a false statement, material to this certification, commits a Class 3 Felony.**

33E-3. Bid-rigging. A person commits the offense of bid-rigging when he knowingly agrees with any person who is, or but for such agreement would be, a competitor of such person concerning any bid submitted or not submitted by such person or another to a unit of State or local government when with the intent that the bid submitted or not submitted will result in the award of a contract to such person or another and he either (1) provides such person or receives from another information concerning the price or other material term or terms of the bid which would otherwise not be disclosed to a competitor in an independent non-collusive submission of bids or (2) submits a bid that is of such a price or other material term or terms that he does not intend the bid to be accepted.

Bid rigging is a Class 3 felony. Any person convicted of this offense or any similar offense of any state or the United States which contains the same elements as this offense shall be barred for 5 years from the date of conviction from contracting with any unit of State or local government. No corporation shall be barred from contracting with any unit of State or local government as a result of a conviction under this Section of any employee or agent of such corporation if the employee so convicted is no longer employed by the corporation and: (1) it has been finally adjudicated not guilty or (2) if it demonstrates to the governmental entity with which it seeks to contract and that entity finds that the commission of the offense was neither authorized, requested, commanded, nor performed by a director, officer or a high managerial agent in behalf of the corporation as provided in paragraph (2) of subsection (a) of Section 5-4 of this Code.

33E-4 Bid rotating. A person commits the offense of bid rotating when, pursuant to any collusive scheme or agreement with another, he engages in a pattern over time (which, for the purposes of this Section, shall include at least 3 contract bids within a period of 10 years, the most recent of which occurs after the effective date of this amendatory Act of 1988) of submitting sealed bids to units of State or local government with the intent that the award of such bids rotates, or is distributed among, persons or business entities which submit bids on a substantial number of the same contracts. Bid rotating is a Class 2 felony. Any person convicted of this offense or any similar offense of any state or the United States which contains the same elements as this offense shall be permanently barred from contracting with any unit of State or local government. No corporation shall be barred from contracting with any unit of State or local government as a result of a conviction under this Section of any employee or agent of such corporation if the employee so convicted is no longer employed by the corporation and: (1) it has been finally adjudicated not guilty or (2) if it demonstrates to the governmental entity with which it seeks to contract and that entity finds that the commission of the offense was neither authorized, requested, commanded, nor performed by a director, officer or a high managerial agent in behalf of the corporation as provided in paragraph (2) of subsection (a) of Section 5-4 of this Code.

Possible violations of Section 33E can be reported to the Office of the Will County State's Attorney at (815) 727-8453 or the Wilmington Police Department at (815) 476-2811.

[Signature]
Signature of Authorized Officer or Agent

8-13-18
Dated

ACCOUNT EXECUTIVE
Title of Authorized Officer or Agent

Confidentiality Statement

The Contractor agrees to treat as confidential all information which may be derived from or be obtained in the course of this contract or which may come into the possession of the contractor or an employee as a result or in connection with this contract. The Contractor will provide all necessary precautions to ensure that all such information is treated as confidential by the contractor and the contractor's employees. All employees of the Contractor will be required to agree to and sign a confidentiality statement when they come to any facilities owned by the City of Wilmington where they may see or have access to confidential, personal, and/or business information.

Confidential information includes all information related to the business of the City of Wilmington and its employees.

I understand that I am bound by a confidentiality and agree to adhere to the conditions within the Contract.

Name of Organization UNI MAX MANAGEMENT CORP

Print Name EJA AMBROS

Signature  Date 8-13-18



Greg Koch
Director of City Services
Crest Hill Public Works
815-741-5122

Tracy Bianco
Operations Supervisor
Forest Preserve District of Will County
www.reconnectwithnature.org
PH:815-545-9743
Email:tbianco@fpdwc.org

Village of Western Springs
740 Hillgrove
Western Springs, Il
708-246-1800
Bill Tomczyk

Mike Mytys (Foreman)
Village of Woodridge
Public Works Department
Office: 630-719-6107
Fax: 630-719-0130
mmytys@vil.woodridge.il.us

Uni Max Management Corp reference list

Criminal Justice Information System Security & Awareness Training



This is to certify that

Eva Ambroz

has successfully completed the

Level 1 CJIS Security Training

May 4, 2018

Certification Date

*This certification expires two
years from the date of issuance.*

May 4, 2020

Expiration Date

INTERGOVERNMENTAL AGREEMENT
between the
COUNTY OF WILL
and
CITY OF WILMINGTON

This intergovernmental agreement is entered into between the County of Will and the City of Wilmington a body corporate and politic; said governmental City of Wilmington desires to enter into an agreement for the County of Will to provide communications system access to the City of Wilmington through the facilities of the County of Will, specifically the Will County owned and operated 800 Mhz county-wide radio system for the purpose of daily, operable communications.

AUTHORITY:

This agreement is entered into by the parties pursuant to the provisions of the Intergovernmental Cooperation Act (5 ILCS 220/1 et seq.).

TERMS:

This agreement shall commence on _____ and will end on December 31, 2027. This agreement may be renewed upon mutual consent of both parties in writing. This agreement supersedes and replaces any and all previous agreements between the parties as they pertain to the use of the County of Will's 800 Mhz county-wide radio system.

1. PARTICIPATION

- 1.1 Commencement Date: Participation under the terms expressed in this agreement commences only upon the signed agreement of all parties involved.
- 1.2 Term: Participation shall continue until December 31, 2027 or at until such time as either the County of Will or the City of Wilmington withdraws from the terms of the agreement.
- 1.3 Withdrawal: Participants may elect to withdraw from further participation. The withdrawal shall be effective 180 days after the postmark on the Notice of Termination sent by registered or certified mail to the chief executive officer of the non-withdrawing participating entity.
- 1.4 Adequate Appropriation: All obligations of the County of Will are conditional upon sufficient appropriation of funds by the Will County Board.

2.

EQUIPMENT AND STANDARDS

- 2.1 It is the responsibility of the City of Wilmington to purchase and utilize equipment compatible with the County of Will 800 MHz radio system.
- 2.2 The County of Will reserves the right to approve or disapprove the final selection and utilization of the above referenced equipment.
- 2.3 The County of Will reserves the right to limit the quantity of equipment that the City of Wilmington may activate in order to preserve the operational integrity of the County of Will 800 MHz radio system.
- 2.4 City of Wilmington shall be responsible for radio configuration and programming of its equipment necessary to access the County of Will 800 MHz radio system, but the Will County Radio System Manager, as agent for the County of Will, shall verify and confirm proper configuration and programming, and may assist in that endeavor.
- 2.5 It is the responsibility of the City of Wilmington to ensure that all radio equipment programmed to operate on the County of Will 800 MHz radio system follows the parameters specified in Attachment A.
- 2.6 System access will not occur until the City of Wilmington has accomplished training in the use of equipment, said training to be provided by the County of Will or it's designee.

3. SERVICES OFFERED

- 3.1 Services offered by the County of Will
 - 3.1.1 Access to shared 800 Mhz talk groups, as defined in Attachment A.
 - 3.1.2 One private talk group. Additional talk groups may be requested and will be considered on a case by case basis, in the sole discretion of the Will County Radio System Manager.
 - 3.1.3 Will County will perform a system audit of City of Wilmington user activity at the request of the City of Wilmington for a fee.
- 3.2 Compensation provided by City of Wilmington
 - 3.2.1 The City of Wilmington will pay no monthly access for utilization of the County of Will 800 MHz radio system for the purpose of daily, operable communications.

3.2.2 No compensation is required for utilization of the shared 911 talk group.

3.2.3 No compensation is required for utilization of the DISASTER talk groups.

3.2.4 No compensation is required for utilization of the MUTUAL AID talk groups.

3.3 Terms of Service

3.3.1 The City of Wilmington agrees to abide by FCC and other applicable rules and standards regulating the use of public safety communications.

3.3.2 The City of Wilmington agrees to abide by the policies and procedures established by the Will County Radio System Manager.

3.3.3 The City of Wilmington understands and agrees that priority status on the system is delegated to public safety entities. Therefore, temporary service interruptions due to system queuing may be experienced during periods of system saturation due to priority traffic.

4. GRIEVANCES

For the purpose of this agreement, a grievance is defined as any difference; complaint or dispute between the parties involved relating to the communications access provided to the City of Wilmington by Will County. Grievance resolution shall be made in accordance with the following steps:

4.1 The Will County Radio System Manager and the City of Wilmington will attempt to arrive at a mutually acceptable solution.

4.2 Should the City of Wilmington Designee and Will County Radio System Manager not be able to come to resolution, the grievance will be forwarded to the Will County Emergency Management Agency Director.

4.3 The Will County Emergency Management Agency Director will review the grievance and recommend the resolution to the grievance. The decision and resolution put forth by the Will County Emergency Management Agency Director shall be final, binding, and conclusive.

5.

INTERRUPTION OF SERVICE

The County of Will assumes no liability for any damages caused by an interruption or suspension of services which prohibits the City of Wilmington from receiving or sending communications via Will County equipment or 800 Mhz county-wide radio system. Further, Will County will not assume liability for any degradation of City of Wilmington service during a period of interruption or suspension due to radio equipment failure.

6. CIVIL LIABILITY

The City of Wilmington hereby agrees to indemnify and hold harmless the County of Will, any Will County employee, agent or contractor, from any and all claims and litigation alleging damage to property, personal injuries, death, or other legal claim resulting from the activities undertaken by the City of Wilmington under the terms of this agreement.

7. LIMITED RESPONSIBILITY

- 7.1 Under the terms of the agreement, Will County does not assume responsibility for dispatching Will County or City of Wilmington personnel in response to calls or requests for assistance directed to the City of Wilmington.
- 7.2 Any and all governmental and public complaints regarding service under the terms of this agreement shall be directed to the Radio System Manager and the City of Wilmington.
 - 7.2.1 Review and resolution shall follow the same procedure specified under the "Grievances" portion of this agreement.
 - 7.2.2 Documentation of the examination of the complaint must be prepared and signed by all representatives involved in determining resolution of the complaint.

8. A PUBLIC CONTRACT

The participants agree and understand that certain federal and Illinois statutory and administrative requirements may apply to this intergovernmental agreement. The participants agree that any and all applicable provisions relating to public contracts are intended to be and are hereby incorporated by reference. Each party will provide, upon written request by the other, written certification of compliance with any statutory or administrative requirement applicable to this agreement. Any certifications so issued by any party shall be deemed part of this agreement.

9. RECORDS

The parties to this agreement shall maintain, for a minimum of five years after the completion of this agreement, adequate books, records and supporting documents to verify the funds available for payment under this agreement, the funds actually issued and/or received by each party, receipts and records concerning the uses and/or deposits of all disbursements passing in conjunction with this agreement.

10. AGREEMENT

The parties hereto have caused this interagency agreement to be executed on this day and year as set forth below.

CITY OF WILMINGTON

COUNTY OF WILL

Name

Name

Title

Title

Date

Date

Attachment A:

All radio equipment operating on the County of Will 800 MHz radio system is required to follow the parameters detailed below:

- All users shall include the “911 Emergency” talk group in each trunked zone that contain talk groups for use on the County of Will 800 Mhz radio system. It is recommended that it be the last talk group in each zone. However, each agency will have the discretion on where to place the talk group in the zone to meet their individual needs.
- All subscriber equipment programmed with the “WILLWARN” talk group shall program as receive only. Exceptions may be made at the discretion of the Will County Radio System Manager.
- If an agency uses the emergency button function, the subscriber equipment must be programed to alarm on a talk group that is monitored 24 hours/day. Law Enforcement agencies shall use their primary dispatch talk group. Fire Service agencies shall use their primary dispatch talk group. All other users shall use the “911 Emergency” talk group.
- All Law Enforcement agencies shall include the “CW POLICE” talk group in their subscriber equipment.
- All Fire Service agencies shall include the “CW FIRE EMS” talk group in their subscriber equipment.
- All Emergency Management agencies shall include the “CW EMA1” and “CW EMA2” talk groups in their subscriber equipment.
- All Transportation/Road District/Public Works agencies shall include the “CW PW HWY” talk group in their subscriber equipment.
- All member agencies of the Three Rivers Manufactures’ Association shall include the following talk groups in their subscriber equipment:
 - RIVER IC
 - RIVER 1
 - RIVER 2
 - RIVER FIRE
 - RIVER POLICE
- Users may program other agency specific talk groups in their subscriber equipment, so long as both agencies agree and it is documented in a written, signed agreement. The Will County Radio System Manager shall be provided a copy of the signed agreement.

Attachment A:

(continued)

- Public Safety Agencies that support the operations of the Three Rivers Manufactures' Association may optionally program the following talk groups in their subscriber equipment with the approval of the Will County Radio System Manager.
 - RIVER IC
 - RIVER 1
 - RIVER 2
 - RIVER FIRE
 - RIVER POLICE

- The following talk groups are RECEIVE ONLY. Requests to transmit on these talk groups will be considered on a case by case basis by the Will County Radio System Manager.
 - Will County EMA VHF Repeater Patch
 - IFERN Patch
 - ISPERN Patch

- For interoperability, all users shall program their subscriber equipment with the Disaster Zone and the BC – BI conventional interoperability zones as listed below (users with 800 MHz only subscriber equipment shall only be required to program the Disaster Zone and the BC Zone):

DISASTER	Zone BC	Zone BD	Zone BE	Zone BF	Zone BG	Zone BH	Zone BI
DSASTR1	8CAL-90D	7CALL50D	7MOB59D	7CALL70D	7MOB79D	7FTAC1D	7MTAC9D
DSASTR2	8TAC-91D	7TAC51D	7MOB59D	7TAC71D	7MOB79D	7FTAC2D	7NTAC10D
DSASTR3	8TAC-92D	7TAC52D	7LAW61D	7TAC72D	7LAW81D	7FTAC3D	7NTAC11D
DSASTR4	8TAC-93D	7TAC53D	7LAW62D	7TAC73D	7LAW82D	7GTAC4D	7NTAC12D
DSASTR5	8TAC-94D	7TAC54D	7FIRE63D	7TAC74D	7FIRE83D	7GTAC5D	7MTAC9
DSASTR6	8CAL-90	7TAC55D	7FIRE64D	7TAC75D	7FIRE84D	7LTAC6D	7NTAC10
DSASTR7	8TAC-91	7TAC56D	7MED65D	7TAC76D	7MED86D	7LTAC7D	7NTAC11
DSASTR8	8TAC-92	7GTAC57D	7MED66D	7GTAC77D	7MED87D	7LTAC8D	7NTAC12
DSASTR9	8TAC-93	7CALL50	7MOB59	7CALL70	7MOB79	7FTAC1	7NTAC12
DSASTR10	8TAC-94	7TAC51	7MOB59	7TAC71	7MOB79	7FTAC2	7NTAC12
DSASTR11	WILLTAC1	7TAC52	7LAW61	7TAC72	7LAW81	7FTAC3	7NTAC12
DSASTR12	WILLTAC2	7TAC53	7LAW62	7TAC73	7LAW82	7GTAC4	7NTAC12
DSASTR13	WILLTACD	7TAC54	7FIRE63	7TAC74	7FIRE83	7GTAC5	7NTAC12
DSASTR14	WILLTACD	7TAC55	7FIRE64	7TAC75	7FIRE84	7LTAC6	7NTAC12
DSASTR15	WILLTACD	7TAC56	7MED65	7TAC76	7MED86	7LTAC7	7NTAC12
911	WILLTACD	7GTAC57	7MED66	7GTAC77	7MED87	7LTAC8	7NTAC12

City of Wilmington

Check Register Meeting Date: August 21, 2018



Check#	Date	Vendor/Employee	Amount
Fund	1	General Corporate Fund	
0	8/8/2018	Payroll Sweep	83,085.13
0	8/8/2018	FedEx	26.30
0	8/8/2018	Paycor	438.06
0	8/8/2018	WEX Bank	3,608.32
0	8/17/2018	Payroll Sweep	80,742.57
0	8/17/2018	Paycor	158.08
0	8/17/2018	IL Funds	1.25
1766	8/21/2018	Amanda Law/ Abstractions	115.17
1767	8/21/2018	Mad Bomber Fireworks	4,000.00
1768	8/21/2018	Waste Management	680.81
1769	8/21/2018	Medinah Shriners	600.00
1770	8/21/2018	Wilmington School District 209U	800.00
1771	8/21/2018	Wilmington Area Amateur Radio Club	600.00
1772	8/21/2018	Wilmington Coalition	300.00
1773	8/21/2018	Wilmington Historical Society	300.00
1774	8/21/2018	Reed Custer Highschool	200.00
1775	8/21/2018	Boy Scout Troop 440	300.00
20277	8/21/2018	Air Gas USA, LLC	63.07
20278	8/21/2018	AT&T	60.42
20279	8/21/2018	Blue Cross Blue Shield of Illinois	1,323.00
20280	8/21/2018	Camz Communications, Inc.	475.00
20281	8/21/2018	Cintas Corporation	619.20
20282	8/21/2018	Constellation New Energy, Inc	5,854.27
20283	8/21/2018	Crowe, LLP	9,316.25
20284	8/21/2018	DTW Inc	1,804.99
20285	8/21/2018	Fisher Auto Parts Inc	331.58
20286	8/21/2018	G W Communications	15.85
20287	8/21/2018	Grundy Redi-Mix Company	1,144.00
20288	8/21/2018	Konica Minolta	348.71
20289	8/21/2018	Language Line Services	31.55
20290	8/21/2018	Menards-Joliet	68.94
20291	8/21/2018	Mold Prevention, Inc.	1,900.00
20292	8/21/2018	Municipal Electronics Inc	140.00
20293	8/21/2018	Office Depot	167.23
20294	8/21/2018	Prairie Material Sales Inc	90.10
20295	8/21/2018	Premier R.E. Holdings of Wilmington	4,680.00
20296	8/21/2018	Ray O Herron Inc	68.99
20297	8/21/2018	Ruettiger Tonelli & Assoc	592.50
20298	8/21/2018	Attn: Financial Services State Treasurer - Idot	1,462.50

20299	8/21/2018	TA Operating, LLC	114.79
20300	8/21/2018	TransUnionsRisk&Alternative Data Solutions, Inc.	25.00
20301	8/21/2018	United Communications Systems Inc	677.12
20302	8/21/2018	Waste Management Of Il SW	693.32
20303	8/21/2018	WatchGuard, Inc.	34,000.00
20304	8/21/2018	WESCOM	20,028.28
20305	8/21/2018	Whitmore Investments Inc	676.42
20306	8/21/2018	Will County Animal Control	560.00
20307	8/21/2018	Will County Recorder	113.25
20308	8/21/2018	Wilmington Collision Center	635.21

TOTAL: 264,037.23

Fund 2 Water Operating M & R Fund

0	8/8/2018	WEX Bank	307.26
0	8/8/2018	Payroll Sweep	13,306.76
0	8/17/2018	Payroll Sweep	15,158.40
0	8/17/2018	INB Bank	2.82
0	8/17/2018	JPMorgan Chase Bank	137.44
0	8/17/2018	IL Funds	586.90
10467	8/21/2018	Accela, Inc. #774375	405.50
10469	8/21/2018	Comcast	104.85
10470	8/21/2018	G W Communications	798.40
10471	8/21/2018	Gasvoda & Associates Inc	3,568.38
10472	8/21/2018	Jack Henry & Associates, Inc.	46.15
10474	8/21/2018	PDC Labs Inc	1,087.75
10475	8/21/2018	Polydyne Inc	3,852.00
10476	8/21/2018	Premier R.E. Holdings of Wilmington	725.00
10477	8/21/2018	Riverside WorkForce Health	73.00
10479	8/21/2018	United Communications Systems Inc	102.30
10481	8/21/2018	Viking Chemical Company	6,548.59
10483	8/21/2018	Waste Management Of Il SW	37,810.90
10484	8/21/2018	Whitmore Investments Inc	31.55

TOTAL: 84,653.95

Fund 3 Sewer Capital Project Fund

10478	8/21/2018	Sunbelt Rentals, Inc.	275.00
-------	-----------	-----------------------	--------

TOTAL: 275.00

Fund 4 Sewer Operating M & R Fund

0	8/8/2018	Payroll Sweep	14,895.32
0	8/8/2018	WEX Bank	466.10
0	8/17/2018	Payroll Sweep	13,524.72
0	8/17/2018	INB Bank	2.81
0	8/17/2018	JPMorgan Chase Bank	137.44
0	8/17/2018	IL Funds	586.90
10467	8/21/2018	Accela, Inc. #774375	405.50
10468	8/21/2018	Alarm Detection Systems, Inc.	126.84

10470	8/21/2018	G W Communications	798.40
10472	8/21/2018	Jack Henry & Associates, Inc.	46.15
10473	8/21/2018	Nestle Water North America	69.89
10479	8/21/2018	United Communications Systems Inc	170.49
10480	8/21/2018	USA Blue Book	704.20
10482	8/21/2018	Vortex Technologies, Inc.	1,780.00
10483	8/21/2018	Waste Management Of II SW	3,166.57
10484	8/21/2018	Whitmore Investments Inc	921.66
TOTAL:			<u>37,802.99</u>

Fund 5 DFC Federal Grant Fund

0	8/17/2018	Better Business Planning Inc.	2,700.85
TOTAL:			<u>2,700.85</u>

Fund 7 ESDA Fund

0	8/8/2018	WEX Bank	641.59
0	8/17/2018	Payroll Sweep	2,250.00
20285	8/21/2018	Fisher Auto Parts Inc	267.36
20286	8/21/2018	G W Communications	15.85
20301	8/21/2018	United Communications Systems Inc	243.85
20304	8/21/2018	WESCOM	2,244.92
20305	8/21/2018	Whitmore Investments Inc	119.05
TOTAL:			<u>5,782.62</u>

Fund 17 Water Capital Project Fund

10476	8/21/2018	Premier R.E. Holdings of Wilmington	1,800.00
10485	8/21/2018	Zenner Performance	12,664.14
TOTAL:			<u>14,464.14</u>
GRAND TOTAL:			<u><u>409,716.78</u></u>

Dennis Vice

Floyd Combes

Steve Evans

John Persic, Jr.

Kevin Kirwin

Frank Studer

Lisa Butler

Fran Tutor

Approved: August 21, 2018



ESI Consultants, Ltd.
Excellence, Service, Integrity

July 1, 2018

Mayor Roy Strong
City of Wilmington
1165 S. Water Street
Wilmington, IL 60481

**Re: South Arsenal at IL 53
ESI Supplement for Construction Services**

Mayor Strong:

Please find attached the requested supplement in the amount of **\$49,846.70** for the above-referenced project. The original contract amount was \$296,462.01 and with the addition of this supplement, the revised amount will be \$346,308.71. This work is subject to IDOT approval of the fees within the EDP funding credits (or other state funding).

This supplement considers the estimated effort to complete the coordination with Nicor for the relocation of their gas main on the west side of IL 53, perform additional coordination to obtain the USACE 404 permit, and to provide construction engineering services (approximately 4-5 weeks) in the summer/fall of 2018 for the installation of the precast end sections for the two culverts under IL 53 and to complete the reconstruction of the ditches on the west side of IL 53.

The installation of the end sections and the grading of the ditches was expected to be completed concurrently with other contract work during the original duration. However, this work is now expected to be completed after substantial completion of the project, the contractor will be granted a time extension and this supplement for construction engineering services is associated with the time extension needed to complete the project in its entirety.

Feel free to contact me at (630) 420-1700 or by e-mail at jchiczewski@esiltd.com if you have any questions or would like to discuss this further.

Sincerely,

A handwritten signature in black ink, appearing to read "J. Chiczewski", followed by the initials "es" in a smaller font.

Joseph M. Chiczewski, P.E.
President

Cc: Mark Reznicek, P.E.
Kevin Siksta, P.E.



Payroll Escalation Table
Fixed Raises
New Formula

FIRM NAME ESI Consultants, Ltd.
PRIME/SUPPLEMENT Prime

DATE 04/25/18
PTB NO. South Arsenal Road at IL 53-SUPPLEMENT

CONTRACT TERM 2 MONTHS
START DATE 5/1/2018
RAISE DATE 5/15/2018

OVERHEAD RATE _____
COMPLEXITY FACTOR _____
% OF RAISE 3.00%

ESCALATION PER YEAR

5/1/2018 - 5/15/2018

5/16/2018 - 7/15/2018

$\frac{0}{2}$

$\frac{2}{2}$

= 0.00%
= 1.0300

103.00%

The total escalation for this project would be:

3.00%



Payroll Rates

FIRM NAME ESI Consultants, Ltd. DATE 04/25/18
PRIME/SUPPLEMENT Prime
PTB NO. South Arsenal Road at IL 53-SUPPLEMENT

ESCALATION FACTOR 3.00%

CLASSIFICATION	CURRENT RATE	ESCALATED RATE
President / Principal **	\$70.00	\$70.00
Vice President / Director**	\$70.00	\$70.00
Senior Manager / Senior Consultant	\$53.63	\$55.24
Senior Structural Project Manager	\$65.05	\$67.00
Senior Project Manager	\$63.50	\$65.41
Structural Project Manager	\$37.00	\$38.11
Project Manager / Project Manager Consultant	\$46.34	\$47.73
Senior Resident Engineer	\$50.00	\$51.50
Resident Engineer 2	\$40.84	\$42.06
Project Engineer/ Resident Engineer 1	\$32.79	\$33.77
Senior Technician 2	\$47.04	\$48.45
Engineer 3	\$28.90	\$29.77
Engineer 2	\$28.50	\$29.36
Engineer 1	\$26.85	\$27.66
Resident Technician / Senior Technician 1	\$33.82	\$34.84
Technician 2	\$23.35	\$24.05
Technician 1 / Engineering Intern	\$15.00	\$15.45
Sr. Admin. Management Consultant	\$46.00	\$47.38
Administrative Associate 3	\$25.49	\$26.25
Administrative Associate 2	\$20.00	\$20.60
Administrative Associate 1	\$15.36	\$15.82
		\$0.00
		\$0.00
		\$0.00
		\$0.00
		\$0.00
		\$0.00
		\$0.00
		\$0.00
		\$0.00
		\$0.00
		\$0.00
		\$0.00
		\$0.00
		\$0.00
		\$0.00
		\$0.00



Cost Estimate of Consultant Services

(Direct Labor Multiple)

04/25/18

Firm ESI Consultants, Ltd.
 Route _____
 Section _____
 County Will
 Job No. C-92-047-11
 PTB & Item South Arsenal Road at IL 53-SUPPLEMENT

Date _____

Overhead Rate _____

Complexity Factor _____

0

DBE DROP BOX	ITEM	MANHOURS (A)	PAYROLL (B)	(2.80+R) TIMES PAYROLL (C)	DIRECT COSTS (D)	SERVICES BY OTHERS (E)	DBE TOTAL (C+D+E)	TOTAL (C+D+E)	% OF GRAND TOTAL
	Utility/Permit Coordination	60	3,756.96	10,519.49				10,519.49	21.10%
	Construction Engineering	236	12,709.72	35,587.22	2,340.00			37,927.22	76.09%
	Program Management (Ruettiger/Tonelli)					1,400.00		1,400.00	2.81%
	TOTALS	296	16,466.68	46,106.70	2,340.00	1,400.00	0.00	49,846.70	100.00%

DBE 0.00%



Average Hourly Project Rates

Route _____
 Section _____
 County Will
 Job No. C-92-047-11
 PTB/Item South Arsenal Road at IL 53-SUPPLEMENT

Consultant ESI Consultants, Ltd.

Date 04/25/18

Sheet 1 OF 1

Payroll Classification	Avg Hourly Rates	Total Project Rates			Utility/Permit Coordination			Construction Engineering			Program Management (Ruettig)								
		Hours	% Part.	Wgtd Avg	Hours	% Part.	Wgtd Avg	Hours	% Part.	Wgtd Avg	Hours	% Part.	Wgtd Avg	Hours	% Part.	Wgtd Avg	Hours	% Part.	Wgtd Avg
President / Principal **	\$70.00	24	8.11%	5.68	12	20.00%	14.00	12	5.08%	3.56									
Vice President / Director**	\$70.00	0																	
Senior Manager / Senior Cons	\$55.24	0																	
Senior Structural Project Mana	\$67.00	0																	
Senior Project Manager	\$65.41	56	18.92%	12.37	32	53.33%	34.88	24	10.17%	6.65									
Structural Project Manager	\$38.11	0																	
Project Manager / Project Mar	\$47.73	0																	
Senior Resident Engineer	\$51.50	216	72.97%	37.58	16	26.67%	13.73	200	84.75%	43.64									
Resident Engineer 2	\$42.06	0																	
Project Engineer/ Resident En	\$33.77	0																	
Senior Technician 2	\$48.45	0																	
Engineer 3	\$29.77	0																	
Engineer 2	\$29.36	0																	
Engineer 1	\$27.66	0																	
Resident Technician / Senior T	\$34.84	0																	
Technician 2	\$24.05	0																	
Technician 1 / Engineering Int	\$15.45	0																	
Sr. Admin. Management Cons	\$47.38	0																	
Administrative Associate 3	\$26.25	0																	
Administrative Associate 2	\$20.60	0																	
Administrative Associate 1	\$15.82	0																	
		0																	
		0																	
		0																	
		0																	
		0																	
		0																	
		0																	
		0																	
		0																	
TOTALS		296	100%	\$55.63	60	100%	\$62.62	236	100%	\$53.85	0	0%	\$0.00	0	0%	\$0.00	0	0%	\$0.00

Municipality Wilmington	L O C A L A G E N C Y	 Illinois Department of Transportation Preliminary/Construction Engineering Services Agreement For Motor Fuel Tax Funds Supplement #1	C O N S U L T A N T	Name ESI Consultants, Ltd
Township				Address 1979 North Mill Street Suite 100
County Will				City Naperville
Section				State IL

THIS AGREEMENT is made and entered into this _____ day of July, 2018 between the above Local Agency (LA) and Consultant (ENGINEER) and covers certain professional engineering services in connection with the improvement of the above PROJECT. Motor Fuel Tax Funds, allotted to the LA by the State of Illinois under the general supervision of the State Department of Transportation, hereinafter called the "DEPARTMENT", will be used entirely or in part to finance ENGINEERING services as described under AGREEMENT PROVISIONS.

WHEREVER IN THIS AGREEMENT or attached exhibits the following terms are used, they shall be interpreted to mean:

Regional Engineer	Deputy Director Division of Highways, Regional Engineer, Department of Transportation
Resident Construction Supervisor	Authorized representative of the LA in immediate charge of the engineering details of the PROJECT
Contractor	Company or Companies to which the construction contract was awarded

Section Description

Name S Arsenal Rd at IL 53 Route _____ Length _____ miles Structure No. _____

Termini IL 53-600 ft north of S Arsenal Rd, 600 ft south of South Arsenal Rd; On South Arsenal Road, 1000 ft east of IL 53

Description

Additional engineering services for the intersection improvement including coordination with Nicor for the relocation of their gas main on the west side of IL 53, additional coordination to obtain the USACE 404 permit, and construction engineering services for the installation of the precast end sections for the two culverts under IL 53 and to complete the grading of the ditch on the west side of IL 53. The work is anticipated to begin in the Summer/Fall of 2018 for a period of approximately 4-5 weeks of construction

Agreement Provisions

The Engineer Agrees,

1. To perform or be responsible for the performance of the following engineering services for the LA in connection with the proposed improvement herein before described, and checked below:
 - a. Make such detailed surveys as are necessary for the preparation of detailed roadway plans.
 - b. Make stream and flood plain hydraulic surveys and gather high water data and flood histories for the preparation of detailed bridge plans.
 - c. Make or cause to be made such soil surveys or subsurface investigations including borings and soil profiles and analyses thereof as may be required to furnish sufficient data for the design of the proposed improvement. Such investigations are to be made in accordance with the current requirements of the DEPARTMENT.
 - d. Make or cause to be made such traffic studies and counts and special intersection studies as may be required to furnish sufficient data for the design of the proposed improvement.

- e. Prepare Army Corps of Engineers Permit, Division of Water Resources Permit, Bridge waterway sketch and/or Channel Change sketch, Utility plan and locations and Railroad Crossing work agreements.
- f. Prepare Preliminary Bridge Design and Hydraulic Report, (including economic analysis of bridge or culvert types) and high water effects on roadway overflows and bridge approaches.

NOTE Four copies to be submitted to the Regional Engineer

- g. Make complete general and detailed plans, special provisions, proposals and estimates of cost and furnish the LA with five (5) copies of the plans, special provisions, proposals and estimates. Additional copies of any or all documents, if required shall be furnished to the LA by the ENGINEER at his actual cost for reproduction.
- h. Furnish the LA with survey and drafts in quadruplicate of all necessary right-of-way dedications, construction easements and borrow pit and channel change agreements including prints of the corresponding plats and staking as required.
- i. Assist the LA in the receipt and evaluation of proposals and the awarding of the construction contract.
- j. Furnish or cause to be furnished for Quality Assurance purposes:
 - (1) Proportioning and testing of concrete mixtures in accordance with the "Manual of Instructions for Concrete Proportioning and Testing" issued by the Bureau of Materials and Physical Research, of the DEPARTMENT and promptly submit reports on forms prepared by said Bureau.
 - (2) Proportioning and testing of bituminous mixtures (including extracting test) in accordance with the "Manual of Instructions for Bituminous Proportioning and Testing" issued by the Bureau of Materials and Physical Research, of the DEPARTMENT, and promptly submit reports on forms prepared by said Bureau.
 - (3) All compaction tests as required by the specifications and report promptly the same on forms prepared by the Bureau of Materials and Physical Research.
 - (4) Quality and sieve analyses on local aggregates to see that they comply with the specifications contained in the contract.
 - (5) Inspection of all materials when inspection is not provided at the sources by the Bureau of Materials and Physical Research, of the DEPARTMENT and submit inspection reports to the LA and the DEPARTMENT in accordance with the policies of the said DEPARTMENT.
- k. Furnish or cause to be furnished
 - (1) A resident construction supervisor, inspectors, and other technical personnel to perform the following work: (The number of such inspectors and other technical personnel required shall be subject to the approval of the LA.)
 - a. Continuous observation of the work and the contractor's operations for compliance with the plans and specifications as construction proceeds, but the ENGINEER does not guarantee the performance of the contract by the contractor.
 - b. Establishment and setting of lines and grades.
 - c. Maintain a daily record of the contractor's activities throughout construction including sufficient information to permit verification of the nature and cost of changes in plans and authorized extra work.
 - d. Supervision of inspectors, proportioning engineers and other technical personnel and the taking and submitting of material samples.
 - e. Revision of contract drawings to reflect as built conditions.
 - f. Preparation and submission to the LA in the required form and number of copies, all partial and final payment estimates, change orders, records and reports required by the LA and the DEPARTMENT.

NOTE: When Federal funds are used for construction and the ENGINEER or the ENGINEER's assigned staff is named as resident construction supervisor, the ENGINEER is required to be prequalified with the STATE in Construction Inspection. The onsite resident construction supervisor and project inspectors shall possess valid Documentation of Contract Quantities certification.

2. That all reports, plans, plats and special provisions to be furnished by the ENGINEER pursuant to this agreement will be in accordance with the current standard specifications and policies of the DEPARTMENT, it being understood that all such reports, plats, plans and drafts shall before being finally accepted, be subject to approval by the LA and the said DEPARTMENT.
3. To attend conferences at any reasonable time when requested to do so by the LA or representatives of the DEPARTMENT.
4. In the event plans, surveys or construction staking are found to be in error during the construction of the PROJECT and revisions of the plans or survey or construction staking corrections are necessary, the ENGINEER agrees that he will perform such work without expense to the LA, even though final payment has been received by him. He shall give immediate attention to these changes so there will be a minimum delay to the contractor.
5. The basic survey notes and sketches, charts, computations and other data prepared or obtained by the ENGINEER pursuant to this agreement will be made available upon request to the LA or the DEPARTMENT without cost and without restriction or limitations as to their use.
6. To make such changes in working plans, including all necessary preliminary surveys and investigations, as may be required after the award of the construction contract and during the construction of the improvement.
7. That all plans and other documents furnished by the ENGINEER pursuant to the AGREEMENT will be endorsed by him and will show his professional seal where such is required by law.
8. To submit, upon request by the LA or the DEPARTMENT a list of the personnel and the equipment he/she proposes to use in fulfilling the requirements of this AGREEMENT.

The LA Agrees,

1. To pay the Engineer as compensation for all services performed as stipulated in paragraphs 1a, 1g, 1i, 1j and 1k, 2, 3, 5 and 6 in accordance with one of the following methods indicated by a check mark:
 - a A sum of money equal to actual hourly rates of principals and employees times a direct labor multiplier of 2.8 (which includes overhead and profit) for the actual hours worked on the project plus any direct project expenses such as travel and equipment and sub-consultants for a total not to exceed \$49,846.70.
 - b A sum of money equal to the percentage of the awarded contract cost for the proposed improvement as approved by the DEPARTMENT based on the following schedule:

Schedule for Percentages Based on Awarded Contract Cost

Awarded Cost Under \$50,000	Percentage Fees	(see note)
	_____	%
	_____	%
	_____	%
	_____	%
	_____	%

Note: Not necessarily a percentage. Could use per diem, cost-plus or lump sum.

2. To pay for services stipulated in paragraphs 1b, 1c, 1d, 1e, 1f and 1h of THE ENGINEER AGREES at the hourly rates stipulated below for personnel assigned to this PROJECT as payment in full to the ENGINEER for the actual time spent in providing these services the hourly rates to include profit, overhead, readiness to serve, insurance, social security and retirement deductions. Traveling and other out-of-pocket expenses will be reimbursed to the ENGINEER at his actual cost. Subject to the approval of the LA, the ENGINEER may sublet all or part of the services provided under paragraphs 1b, 1c, 1d, 1e, 1f, 1j and 1k of THE ENGINEER AGREES. If the ENGINEER sublets all or a part of this work, the LA will pay the cost to the ENGINEER plus a five (5) percent service charge. "Cost to ENGINEER" to be verified by furnishing the LA and the DEPARTMENT copies of invoices from the party doing the work. The classifications of the employees used in the work should be consistent with the employee classifications for the services performed. If the personnel of the firm including the Principal Engineer perform routine services that should normally be performed by lesser-salaried personnel, the wage rate billed for such services shall be commensurate with the work performed.

Grade Classification of Employee	Hourly Rate
Principal Engineer	_____
Resident Construction Supervisor	_____
Chief of Party	_____
Instrument Man	_____
Rodmen	_____
Inspectors	_____
_____	_____
_____	_____
_____	_____
_____	_____

The hourly rates itemized above shall be effective the date the parties, hereunto entering this AGREEMENT, have affixed their hands and seals and shall remain in effect until 12/31/2018. In event the services of the ENGINEER extend beyond 12/31/2018, the hourly rates will be adjusted yearly by addendum to this AGREEMENT to compensate for increases or decreases in the salary structure of the ENGINEER that are in effect at that time.

3. That payments due the ENGINEER for services rendered pursuant to this AGREEMENT will be made as soon as practicable after the services have been performed, in accordance with the following schedule:
 - a. Upon completion of detailed plans, special provisions, proposals and estimate of cost - being the work required by paragraphs 1a through 1g under THE ENGINEER AGREES - to the satisfaction of the LA and their approval by the DEPARTMENT, 90 percent of the total fee based on the above fee schedule and the approved estimate of cost.
 - b. Upon award of the contract for the improvement by the LA and its approval by the DEPARTMENT, 100 percent of the total fee (excluding any fees paragraphs 1j and 1k of the ENGINEER AGREES), based on the above fee schedule and the awarded contract cost, less any previous payment.
 - c. Upon completion of the construction of the improvement, 90 percent of the fee due for services stipulated in paragraphs 1j and 1k.
 - d. Upon completion of all final reports required by the LA and the DEPARTMENT and acceptance of the improvement by the DEPARTMENT, 100 percent of the total fees due under this AGREEMENT, less any amounts previously paid.

By mutual agreement, partial payments, not to exceed 90 percent of the amount earned, may be made from time to time as the work progresses.

4. That should the improvements be abandoned at any time after the ENGINEER has performed any part of the services provided for in paragraphs 1a and 1g, and prior to the completion of such services the LA shall reimburse the ENGINEER for his actual costs plus 180% percent incurred up to the time he is notified in writing of such abandonment "actual cost" being defined as material costs plus actual payrolls, insurance, social security and retirement deductions. Traveling and other out-of-pocket expenses will be reimbursed to the ENGINEER at his actual cost.
5. That should the LA require changes in any of the detailed plans, specifications or estimates (except for those required pursuant to paragraph 4 of THE ENGINEER AGREES) after they have been approved by the DEPARTMENT, the LA will pay the ENGINEER for such changes on the basis of actual cost plus 180% percent to cover profit, overhead and readiness to serve - "actual cost" being defined as in paragraph 4 above. It is understood that "changes" as used in this paragraph shall in no way relieve the ENGINEER of his responsibility to prepare a complete and adequate set of plans.
6. That should the LA extend completion of the improvement beyond the time limit given in the contract, the LA will pay the ENGINEER, in addition to the fees provided herein, his actual cost incurred beyond such time limit - "actual cost" being defined as in paragraph 4 above.
7. To submit approved forms BC 775 and BC 776 with this AGREEMENT when federal funds are used for construction.

It is Mutually Agreed,

1. That any difference between the ENGINEER and the LA concerning the interpretation of the provisions of this AGREEMENT shall be referred to a committee of disinterested parties consisting of one member appointed by the

ENGINEER one member appointed by the LA and a third member appointed by the two other members for disposition and that the committee's decision shall be final.

2. This AGREEMENT may be terminated by the LA upon giving notice in writing to the ENGINEER at his last known post office address. Upon such termination, the ENGINEER shall cause to be delivered to the LA all drawings, specifications, partial and completed estimates and data if any from traffic studies and soil survey and subsurface investigations with the understanding that all such material becomes the property of the LA. The ENGINEER shall be paid for any services completed and any services partially completed in accordance with Section 4 of THE LA AGREES.
3. That if the contract for construction has not been awarded one year after the acceptance of the plans by the LA and their approval by the DEPARTMENT, the LA will pay the ENGINEER the balance of the engineering fee due to make 100 percent of the total fees due under the AGREEMENT, based on the estimate of cost as prepared by the ENGINEER and approved by the LA and the DEPARTMENT.
4. That the ENGINEER warrants that he/she has not employed or retained any company or person, other than a bona fide employee working solely for the ENGINEER, to solicit or secure this contract and that he/she has not paid or agreed to pay any company or person, other than a bona fide employee working solely for the ENGINEER, any fee, commission, percentage, brokerage fee, gifts or any other consideration contingent upon or resulting from the award or making of this contract. For breach or violation of this warranty the LA shall have the right to annul this contract without liability.

IN WITNESS WHEREOF, the parties have caused this AGREEMENT to be executed in quadruplicate counterparts, each of which shall be considered as an original by their duly authorized offices.

Executed by the LA:

_____ of the
City of Wilmington
(Municipality/Township/County)

ATTEST:

State of Illinois, acting by and through its

By _____,

_____ ,

Clerk

By _____

(Seal)

Title:

Executed by the ENGINEER:

ATTEST:

By _____

Title:

Title:

Approved

Date
Department of Transportation

Regional Engineer



ESI Consultants, Ltd.
Excellence, Service, Integrity

Mayor Roy Strong
City of Wilmington
1165 S. Water Street
Wilmington, IL 60481

July 1, 2018

Re: Proposal for Supplemental Professional Engineering Services
Phased Construction of Intersection Improvements – Stage 2
South Arsenal Road at Illinois Route 53
Wilmington, Illinois

Dear Mayor Strong:

As Stage 1 of the intersection work nears completion, the City's goal of completing a substantial portion of the proposed work without the acquisition of additional right-of-way (Stage 1) has been realized. This included construction of the permanent traffic signals which IDOT had been anxiously anticipating. Please recall that we had originally completed the full build out of the intersection, however when the City had ROW delays we were directed to proceed a verbally approved supplement to revise the plans to avoid ROW take while installing the permanent traffic signals (as required by IDOT as a condition of the temporary traffic signal approval) and the majority of the work along IL 53.

Pursuant your direction, ESI Consultants, Ltd. (ESI) has prepared the attached proposal for supplemental engineering to revise the original set of plans to reflect the completed Stage 1 work and detail the remaining construction work for Stage 2. Included is a discussion of the various design elements that remain to be performed. ESI requests a fee of **\$102,750** for the additional engineering services related to plan revisions for the South Arsenal Road at Illinois Route 53 Intersection Improvement Project. It is our opinion that City of Wilmington may request that IDOT allow the City to utilize a portion of the remaining Economic Development Program (EDP) credits need to fund this additional effort. Alternatively, this would also be eligible for MFT funding or other City funding.

Please note that based on our estimates there are sufficient funds remaining in the EDP credits to cover the costs of this supplemental Design work as well as the Construction and Construction Engineering cost. We believe can have these plans and related permitting completed in time for Spring 2019 construction is we are authorized to proceed soon.

If you should find this proposal acceptable, please process this as quickly as practical for approval and execution in order to meet the desired schedule goals.

Please feel free to call me directly at (630) 420-1700 or contact me by e-mail at mreznicek@esiltd.com if you have any questions or comments.

Sincerely,

ESI CONSULTANTS, LTD.

Mark Reznicek, P.E.
Senior Project Manager

Joseph M. Chiczewski, P.E.
President

Project Understanding

ESI Consultants (ESI) had originally prepared Plans, Specifications and Estimates for the intersection of South Arsenal Road at IL 53 to include auxiliary lanes along IL 53, a 5 lane cross section on S Arsenal Rd (including dual left turns and single right turn lane as well as 2 received lanes on S Arsenal Road) and new traffic signals. After the plans were completed the City determined that the small parcel of land required for this full improvement would be too costly and too lengthy of a process to acquire so the City Administrator approved supplemental fees and directed ESI to revise the plans to reduce the footprint and eliminate the need for any land acquisition while still installing the permanent traffic signals. The reduced scope was referred to as Phase 1 of the intersection improvement and generally involved the reconstruction of the three existing lanes along S Arsenal Road.

This Phase 1 design revision was completed in 2016 and the construction is nearing completion at the time of this supplement. For the full improvement benefits, Phase 2 will require a new set of plans to be completed to further widen S Arsenal Road for the full turn lanes and receiving lanes at the intersection. Phase 2 is also necessary for the drainage improvements to be more effective. Additionally the City of Wilmington has requested the addition of a multi-use path to extend from N River Road to the north side of South Arsenal Road to improve the region's transportation options (allowing for bicycles and pedestrians) and connectivity (note with the addition of a path the right of way may have a slight adjust for the intersection crossing).

This Supplement assumes that the ESR and the IDS, previously approved by IDOT, will not require revisions as the area has already been reviewed for the full build-out conditions.

The following is a brief discussion of the notable design elements as they relate to Phase 2 construction work:

1. Roadway
 - A barrier median and two lanes will be added to the south side of South Arsenal Road. These will serve as the two receiving lanes for traffic from IL Route 53.
 - Note that the Phase 1 project completed all of the proposed improvements on IL Route 53 with the exception of the northbound acceleration lane which the City has eliminated to preclude relocation of their sanitary force main. IDOT had previously confirmed that the acceleration lane is not required for the ultimate improvement.
2. Drainage
 - IL 53 South Culvert – The east end of the culvert will need to be extended to accommodate the proposed bike path. We anticipate that this will also require a junction box to receive drainage flow from the intersecting ditches.
 - SAR Culvert – The south half of the proposed culvert will be constructed as part of Phase 2. It will connect to the north half which was completed during Phase 1.
3. Traffic Signals
 - While the Phase 1 work generally located the traffic signals at locations compatible with the Phase 2 work, there is one traffic signal post located in the Southeast corner which could not be placed in its final location and therefore will require relocation during Phase 2.
 - Traffic signals plans will need to be updated to allow for pedestrian/bicyclist crossing.

4. Utilities

- Water Main – Phase 2 construction work will include relocation of water main along South Arsenal Road to the proposed utility easement. Permitting through IEPA will be required.
- Nicor gas main – Coordination with Nicor for relocation of their gas line which currently is located within an easement and falls under the proposed curb and gutter. Nicor's work, which is reimbursable, will be paid through the EDP credits.
- ComEd Power Poles – Coordination with ComEd for relocation of their utility poles is anticipated for Phase 2 construction.

5. Multi-Use Path

- A multi-use path will be provided along the east side of IL 53 from N River Road where it will connect to the existing path at that location, to north of South Arsenal Road (potentially extending to Midewin and / or future paths into the JADA at Prologis Park site).

Scope of Services

The following tasks constitute ESI's additional scope of services:

1. Supplemental Survey Pick up:
 - Up to 2 days of survey work for areas along the proposed path and to address any questions regarding the final "as built" condition after completion of Stage 1
2. Alternative evaluations for the Multiuse path – evaluate up to 3 alternatives for the path location and cross section. Meet with City staff and Midewin representatives up to a total of 2 meetings to determine the preferred location. Include path in pre-final plan sheets (up to 2 additional sheets)
3. Revise Traffic Signal Plans to incorporate bicyclist/pedestrian crossing.
4. Drainage Studies - This effort will include drainage calculations and design to ensure proper sizing of any additional storm sewer runs and a Technical Memorandum (abbreviated) to discuss the drainage impacts of adding the multi-use path to the current proposed plans.
5. Prefinal Contract Plans and Documents - Revise current Contract Plans, Specifications, and Estimates according to IDOT's Bureau of Local Road's and Streets Manual, their policies and procedures as they relate to processing of contract plans for MFT funding.
 - a) Contract Plans requiring revisions are anticipated to include
 - Cover Sheet
 - Summary of Quantities - Task includes preparation of final quantity take-offs
 - Alignment and ties sheet
 - Typical Sections – Existing (Phase 1) and Proposed (Phase 2)
 - Existing and Proposed Plan and Profile
 - South Arsenal Road
 - Illinois Route 53
 - Include path in pre-final plan sheets (up to 2 additional sheets)
 - Suggested Staging / Maintenance of Traffic Plans
 - Erosion Control Plan
 - Drainage and Utilities

- Intersection Details
 - Pavement Jointing Sheet
 - Pavement Marking and Signing
 - Landscaping Sheets
 - Traffic Signal Plans – Relocated post and pedestrian crossing
 - Water Main Plans
 - Lighting Sheets (2 additional light poles along south side)
 - Precast Box Culvert Details (IL 53 at Multi-Use Path) – Structural design required
 - Precast Box Culvert Details (SAR) – Structural design required
 - Cross Sections
- b) Preparation of the Local Public Agency Formal Contract Proposal booklet including all Specifications according to the latest Standard Specifications for Road and Bridge Construction
- c) Estimates shall include:
- Estimate of Construction Cost (with prices and percentage breakdowns as required by IDOT)
 - Estimate of Time Required
6. Final Plans
- a. Update Plans, Specifications and Estimates to address Prefinal Plan comments
 - b. IDOT Coordination including a disposition of comments.
 - c. Update Plat/Property Exhibit for Land Acquisition (Geotech Inc.)
7. Permits and Utility Coordination
- IEPA / Water Main Permit
 - Storm Water Pollution Prevention Plan (SWPPP)
 - Nicor
 - Com Ed
 - ATT
 - BP Pipeline (if necessary)
8. Bidding Support
- Respond to RFI
 - Hold up to 1 pre-construction meeting
9. Meetings and Administration
- IDOT Coordination
 - City Coordination
 - Project planning , scheduling, controls and invoicing
10. Program Management (Ruettiger/Tonelli)

Exclusions

This agreement does not include services for:

- Construction Engineering Services



Schedule

Upon approval of this agreement the remaining effort will be completed within approximately 4 months to allow construction to be initiated in 2018 should the required right-of-way be secured.

Compensation

ESI Consultants, Ltd (ESI) proposes to provide the necessary professional consulting services for a lump sum fee of **\$102,750**.

The estimated hours and fees to complete each task detailed by assignment are included on the attached spreadsheets (Exhibit A). For progress billing purposes this will be billed based on the approximate percent of completion as determined by the engineer (generally estimated based on a direct labor multiplier plus direct expenses).

END



Average Hourly Project Rates

Route _____
 Section _____
 County Will
 Job No. _____
 PTB/Item S Arsenal Road at IL 53 - Phase 2 Construction

Consultant ESI Consultants, Ltd.

Date 04/25/18

Sheet 1 OF 2

Payroll Classification	Avg Hourly Rates	Total Project Rates			Supplmental Survey Pick up			Multi-Use Path Alternative Stud			Traffic Signal Ped Accomodati			Drainage Studies			Pre-final engineering		
		Hours	% Part.	Wgtd Avg	Hours	% Part.	Wgtd Avg	Hours	% Part.	Wgtd Avg	Hours	% Part.	Wgtd Avg	Hours	% Part.	Wgtd Avg	Hours	% Part.	Wgtd Avg
President / Principal **	\$70.00	66	8.17%	5.72				6	6.67%	4.67	2	4.00%	2.80	4	10.00%	7.00	12	4.96%	3.47
Vice President / Director**	\$70.00	0																	
Senior Manager / Senior Cons	\$54.57	0																	
Senior Structural Project Mana	\$66.19	0																	
Senior Project Manager	\$63.10	132	16.34%	10.31	4	7.69%	4.85	12	13.33%	8.41	8	16.00%	10.10	12	30.00%	18.93	24	9.92%	6.26
Structural Project Manager	\$37.65	0																	
Project Manager / Project Man	\$47.15	8	0.99%	0.47															
Senior Resident Engineer	\$49.01	0																	
Resident Engineer 2	\$41.55	0																	
Project Engineer/ Resident En	\$33.36	212	26.24%	8.75				36	40.00%	13.35	20	40.00%	13.35	12	30.00%	10.01	80	33.06%	11.03
Senior Technician 2	\$47.86	152	18.81%	9.00	24	46.15%	22.09				20	40.00%	19.14	8	20.00%	9.57	60	24.79%	11.87
Engineer 3	\$29.41	30	3.71%	1.09															
Engineer 2	\$29.00	0																	
Engineer 1	\$27.32	160	19.80%	5.41	24	46.15%	12.61	36	40.00%	10.93							60	24.79%	6.77
Resident Technician / Senior T	\$34.41	0																	
Technician 2	\$23.76	0																	
Technician 1 / Engineering Int	\$15.26	0																	
Sr. Admin. Management Cons	\$46.81	0																	
Administrative Associate 3	\$25.94	48	5.94%	1.54										4	10.00%	2.59	6	2.48%	0.64
Administrative Associate 2	\$20.35	0																	
Administrative Associate 1	\$15.63	0																	
		0																	
		0																	
		0																	
		0																	
		0																	
		0																	
		0																	
		0																	
		0																	
TOTALS		808	100%	\$42.29	52	100%	\$39.55	90	100%	\$37.35	50	100%	\$45.39	40	100%	\$48.10	242	100%	\$40.04

Average Hourly Project Rates

Route _____
 Section _____
 County Will
 Job No. _____
 PTB/Item S Arsenal Road at IL 53 - Phase 2 Contruction

Consultant ESI Consultants, Ltd.

Date 04/25/18

Sheet 2 OF 2

Payroll Classification	Avg Hourly Rates	Final Engineering			Permits and Utility Coordinatio			Bidding Support			Meetings and Admininstration			Program Mngmnt (Ruettiger/To					
		Hours	% Part.	Wgtd Avg	Hours	% Part.	Wgtd Avg	Hours	% Part.	Wgtd Avg	Hours	% Part.	Wgtd Avg	Hours	% Part.	Wgtd Avg	Hours	% Part.	Wgtd Avg
President / Principal **	\$70.00	8	4.26%	2.98	6	14.29%	10.00	4	12.50%	8.75	24	33.33%	23.33						
Vice President / Director**	\$70.00																		
Senior Manager / Senior Cons	\$54.57																		
Senior Structural Project Mana	\$66.19																		
Senior Project Manager	\$63.10	24	12.77%	8.05	12	28.57%	18.03	12	37.50%	23.66	24	33.33%	21.03						
Structural Project Manager	\$37.65																		
Project Manager / Project Mar	\$47.15				8	19.05%	8.98												
Senior Resident Engineer	\$49.01																		
Resident Engineer 2	\$41.55																		
Project Engineer/ Resident En	\$33.36	40	21.28%	7.10	12	28.57%	9.53	12	37.50%	12.51									
Senior Technician 2	\$47.86	40	21.28%	10.18															
Engineer 3	\$29.41	30	15.96%	4.69															
Engineer 2	\$29.00																		
Engineer 1	\$27.32	40	21.28%	5.81															
Resident Technician / Senior	\$34.41																		
Technician 2	\$23.76																		
Technician 1 / Engineering Int	\$15.26																		
Sr. Admin. Management Cons	\$46.81																		
Administrative Associate 3	\$25.94	6	3.19%	0.83	4	9.52%	2.47	4	12.50%	3.24	24	33.33%	8.65						
Administrative Associate 2	\$20.35																		
Administrative Associate 1	\$15.63																		
TOTALS		188	100%	\$39.65	42	100%	\$49.01	32	100%	\$48.16	72	100%	\$53.01	0	0%	\$0.00	0	0%	\$0.00



Payroll Escalation Table
Fixed Raises
New Formula

FIRM NAME ESI Consultants, Ltd.
PRIME/SUPPLEMENT SUPPLEMENT

DATE 04/25/18
PTB NO. S Arsenal Road at IL 53 - Phase 2 Construction

CONTRACT TERM 12 MONTHS
START DATE 11/1/2017
RAISE DATE 4/1/2018

OVERHEAD RATE _____
COMPLEXITY FACTOR _____
% OF RAISE 3.00%

ESCALATION PER YEAR

11/1/2017 - 4/1/2018

4/2/2018 - 11/1/2018

$\frac{5}{12}$

$\frac{7}{12}$

= 41.67%
= 1.0175

60.08%

The total escalation for this project would be:

1.75%



Payroll Rates

FIRM NAME ESI Consultants, Ltd. **DATE** 04/25/18
PRIME/SUPPLEMENT SUPPLEMENT
PTB NO. S Arsenal Road at IL 53 - Phase 2 Construction

ESCALATION FACTOR 1.75%

CLASSIFICATION	CURRENT RATE	ESCALATED RATE
President / Principal **	\$70.00	\$70.00
Vice President / Director**	\$70.00	\$70.00
Senior Manager / Senior Consultant	\$53.63	\$54.57
Senior Structural Project Manager	\$65.05	\$66.19
Senior Project Manager	\$62.01	\$63.10
Structural Project Manager	\$37.00	\$37.65
Project Manager / Project Manager Consultant	\$46.34	\$47.15
Senior Resident Engineer	\$48.17	\$49.01
Resident Engineer 2	\$40.84	\$41.55
Project Engineer/ Resident Engineer 1	\$32.79	\$33.36
Senior Technician 2	\$47.04	\$47.86
Engineer 3	\$28.90	\$29.41
Engineer 2	\$28.50	\$29.00
Engineer 1	\$26.85	\$27.32
Resident Technician / Senior Technician 1	\$33.82	\$34.41
Technician 2	\$23.35	\$23.76
Technician 1 / Engineering Intern	\$15.00	\$15.26
Sr. Admin. Management Consultant	\$46.00	\$46.81
Administrative Associate 3	\$25.49	\$25.94
Administrative Associate 2	\$20.00	\$20.35
Administrative Associate 1	\$15.36	\$15.63
		\$0.00
		\$0.00
		\$0.00

Municipality City of Wilmington	L O C A L A G E N C Y	 Illinois Department of Transportation Preliminary Engineering Services Agreement For Motor Fuel Tax Funds Supplement #3	C O N S U L T A N T	Name ESI Consultants, Ltd.
Township				Address 1979 N. Mill Street
County Will				City Naperville
Section 08-00042-00-WR				State Illinois

THIS AGREEMENT is made and entered into this _____ day of July, 2018 between the above Local Agency (LA) and Consultant (ENGINEER) and covers certain professional engineering services in connection with the improvement of the above SECTION. Motor Fuel Tax Funds, allotted to the LA by the State of Illinois under the general supervision of the State Department of Transportation, hereinafter called the "DEPARTMENT", will be used entirely or in part to finance ENGINEERING services as described under AGREEMENT PROVISIONS.

Section Description

Name South Arsenal Road

Route _____ Length 0.3 Mi. 1,588 FT (Structure No. N/A)

Termini at Illinois Route 53 Intersection

Description:

This project involves additional planning and design engineering services required to phase construct the intersection improvement of South Arsenal Road at Illinois Route 53. Additional services include preliminary engineering, environmental coordination, drainage studies, structural redesign of drainage structures, and plan revisions for Stage 2 construction of South Arsenal Road as detailed in the attached scope of work.

Agreement Provisions

The Engineer Agrees,

1. To perform or be responsible for the performance of the following engineering services for the LA, in connection with the proposed improvements herein before described, and checked below:
 - a. Make such detailed surveys as are necessary for the preparation of detailed roadway plans
 - b. Make stream and flood plain hydraulic surveys and gather high water data, and flood histories for the preparation of detailed bridge plans.
 - c. Make or cause to be made such soil surveys or subsurface investigations including borings and soil profiles and analyses thereof as may be required to furnish sufficient data for the design of the proposed improvement. Such investigations are to be made in accordance with the current requirements of the DEPARTMENT.
 - d. Make or cause to be made such traffic studies and counts and special intersection studies as may be required to furnish sufficient data for the design of the proposed improvement.
 - e. Prepare Army Corps of Engineers Permit, Department of Natural Resources-Office of Water Resources Permit, Bridge waterway sketch, and/or Channel Change sketch, Utility plan and locations, and Railroad Crossing work agreements.
 - f. Prepare Preliminary Bridge design and Hydraulic Report, (including economic analysis of bridge or culvert types) and high water effects on roadway overflows and bridge approaches.
 - g. Make complete general and detailed plans, special provisions, proposals and estimates of cost and furnish the LA with five (5) copies of the plans, special provisions, proposals and estimates. Additional copies of any or all documents, if required, shall be furnished to the LA by the ENGINEER at his actual cost for reproduction.
 - h. Furnish the LA with survey and drafts in quadruplicate of all necessary right-of-way dedications, construction easement and borrow pit and channel change agreements including prints of the corresponding plats and staking as required.

Note: Four copies to be submitted to the Regional Engineer

- i. Assist the LA in the tabulation and interpretation of the contractors' proposals
 - j. Prepare the necessary environmental documents in accordance with the procedures adopted by the DEPARTMENT's Bureau of Local Roads & Streets.
 - k. Prepare the Project Development Report when required by the DEPARTMENT.
- (2) That all reports, plans, plats and special provisions to be furnished by the ENGINEER pursuant to the AGREEMENT, will be in accordance with current standard specifications and policies of the DEPARTMENT. It is being understood that all such reports, plats, plans and drafts shall, before being finally accepted, be subject to approval by the LA and the DEPARTMENT.
- (3) To attend conferences at any reasonable time when requested to do so by representatives of the LA or the Department.
- (4) In the event plans or surveys are found to be in error during construction of the SECTION and revisions of the plans or survey corrections are necessary, the ENGINEER agrees that he will perform such work without expense to the LA, even though final payment has been received by him. He shall give immediate attention to these changes so there will be a minimum delay to the Contractor.
- (5) That basic survey notes and sketches, charts, computations and other data prepared or obtained by the Engineer pursuant to this AGREEMENT will be made available, upon request, to the LA or the DEPARTMENT without cost and without restriction or limitations as to their use.
- (6) That all plans and other documents furnished by the ENGINEER pursuant to this AGREEMENT will be endorsed by him and will show his professional seal where such is required by law.

The LA Agrees,

1. To pay the ENGINEER as compensation for all services performed as stipulated in paragraphs 1b, 1f, & 1k in accordance with one of the following methods indicated by a check mark:
- a. A sum of money equal to _____ percent of the awarded contract cost of the proposed improvement as approved by the DEPARTMENT.
 - b. A sum of money equal to the percent of the awarded contract cost for the proposed improvement as approved by the DEPARTMENT based on the following schedule:

Schedule for Percentages Based on Awarded Contract Cost

Awarded Cost	Percentage Fees	(see note)
Under \$50,000	_____	%
	_____	%
	_____	%
	_____	%
	_____	%

Note: Not necessarily a percentage. Could use per diem, cost-plus or lump sum

2. To pay for additional services stipulated in paragraphs 1a, 1c, 1d, 1e, 1f, 1g, 1h, 1i, 1j, 1k, 2, 3, 5 and 6 of the ENGINEER AGREES a lump sum of \$102,750. This fee has been developed based on the attached Cost Estimate of Consultant Services (see Attachment A) utilizing a Direct Labor Multiplier of 2.7. Subject to the approval of the LA, the ENGINEER may sublet all or part of the services provided under the paragraph 1a, 1b, 1c, 1d, 1e, 1f, 1h, 1j & 1k.
3. That payments due the ENGINEER for services rendered in accordance with this AGREEMENT will be made as soon as practicable after the services have been performed in accordance with the following schedule:
- a. Upon completion of detailed plans, special provisions, proposals and estimate of cost - being the work required by paragraphs 1a through 1g under THE ENGINEER AGREES - to the satisfaction of the LA and their approval by the DEPARTMENT, 100 percent of the total fee due under this AGREEMENT based on the approved estimate of cost.
 - b. By Mutual agreement, partial payments may be made from time to time as the work progresses.

4. That, should the improvement be abandoned at any time after the ENGINEER has performed any part of the services provided for in paragraphs 1a, through 1h and prior to the completion of such services, the LA shall reimburse the ENGINEER for his actual costs plus 10 percent incurred up to the time he is notified in writing of such abandonment -"actual cost" being defined as in paragraph 2 of THE LA AGREES
5. That, should the LA require changes in any of the detailed plans, specifications or estimates except for those required pursuant to paragraph 4 of THE ENGINEER AGREES, after they have been approved by the DEPARTMENT, the LA will pay the ENGINEER for such changes on the basis of actual cost plus 10 percent to cover profit, overhead and readiness to serve -"actual cost" being defined as in paragraph 2 of THE LA AGREES. It is understood that "changes" as used in this paragraph shall in no way relieve the ENGINEER of his responsibility to prepare a complete and adequate set of plans and specifications.

It is Mutually Agreed,

1. That any difference between the ENGINEER and the LA concerning their interpretation of the provisions of this Agreement shall be referred to a committee of disinterested parties consisting of one member appointed by the ENGINEER, one member appointed by the LA and a third member appointed by the two other members for disposition and that the committee's decision shall be final.
2. This AGREEMENT may be terminated by the LA upon giving notice in writing to the ENGINEER at his last known post office address. Upon such termination, the ENGINEER shall cause to be delivered to the LA all surveys, permits, agreements, preliminary bridge design & hydraulic report, drawings, specifications, partial and completed estimates and data, if any from traffic studies and soil survey and subsurface investigations with the understanding that all such material becomes the property of the LA. The ENGINEER shall be paid for any services completed and any services partially completed in accordance with Section 4 of THE LA AGREES.
3. That if the contract for construction has not been awarded one year after the acceptance of the plans by the LA and their approval by the DEPARTMENT, the LA will pay the ENGINEER the balance of the engineering fee due to make 100 percent of the total fees due under this AGREEMENT, based on the estimate of cost as prepared by the ENGINEER and approved by the LA and the DEPARTMENT.
4. That the ENGINEER warrants that he/she has not employed or retained any company or person, other than a bona fide employee working solely for the ENGINEER, to solicit or secure this contract, and that he/she has not paid or agreed to pay any company or person, other than a bona fide employee working solely for the ENGINEER, any fee, commission, percentage, brokerage fee, gifts or any other consideration, contingent upon or resulting from the award or making of this contract. For Breach or violation of this warranty the LA shall have the right to annul this contract without liability.
5. That the original agreement, which the LA executed on February 27, 2012, and provided verbal authorization to start work on March 13, 2012, remains in full force and effect and that this work will be completed in an orderly fashion and delays in review or processing by the City or IDOT will result in an increased fee .

IN WITNESS WHEREOF, the parties have caused the AGREEMENT to be executed in quadruplicate counterparts, each of which shall be considered as an original by their duly authorized officers.

Executed by the LA:

City of Wilmington of the
(Municipality/Township/County)

ATTEST:

State of Illinois, acting by and through its

By _____

Clerk

By _____

(Seal)

Title _____

Executed by the ENGINEER:

ESI Consultants, Ltd.

ATTEST:

By _____

By _____

Title _____

Title _____

Approved
_____ Date
Department of Transportation
_____ Regional Engineer



ESI Consultants, Ltd.
Excellence, Service, Integrity

July 1, 2018

Mayor Roy Strong
City of Wilmington
1165 S. Water Street
Wilmington, IL 60481

**Re: Peotone Road at IL 53
ESI Proposal for Construction Services**

Mayor Strong:

We are pleased to submit the proposal for construction engineering services required for the improvement of the IL Route 53 intersection with South Arsenal Road.

Attached is the Construction Engineering Services Agreement and supporting documentation including the Cost Estimate of Consultant Services in the amount of \$199,927.67. If you find this proposal to be acceptable, please execute four copies of this agreement and return for further processing by IDOT.

We appreciate the opportunity to continue providing services for the City on this project.

Feel free to contact me at (630) 420-1700 or by e-mail at jchiczewski@esiltd.com if you have any questions or would like to discuss this further.

Sincerely,

A handwritten signature in black ink, appearing to read "J. Chiczewski", with a small "es" written at the end of the signature.

Joseph M. Chiczewski, P.E.
President

Cc: Mark Reznicek, P.E.
Kevin Siksta, P.E.

**PAYROLL ESCALATION TABLE
FIXED RAISES**

FIRM NAME ESI Consultants Ltd.
PRIME/SUPPLEMENT Prime

DATE 04/25/18
PTB NO. IL 53 at Peotone Rd.

CONTRACT TERM 5 MONTHS
START DATE 6/1/2018
RAISE DATE 1/1/2019

OVERHEAD RATE 141.49%
COMPLEXITY FACTOR 0
% OF RAISE 3.00%

ESCALATION PER YEAR

6/1/2018 - 10/31/2018

5
5

= 100.00%
= 1.0000

The total escalation for this project would be:

0.00%

PAYROLL RATES

FIRM NAME ESI Consultants Ltd. **DATE** 04/25/18
PRIME/SUPPLEMENT Prime
PSB NO. IL 53 at Peotone Rd.

ESCALATION FACTOR **0.00%**

CLASSIFICATION	CURRENT RATE	CALCULATED RATE
President / Principal **	\$70.00	\$70.00
Vice President / Director**	\$70.00	\$70.00
Senior Manager / Senior Consultant	\$53.63	\$53.63
Senior Structural Project Manager	\$65.05	\$65.05
Senior Project Manager	\$63.50	\$63.50
Structural Project Manager	\$37.00	\$37.00
Project Manager / Project Manager Consultant	\$46.34	\$46.34
Senior Resident Engineer	\$50.00	\$50.00
Resident Engineer 2	\$40.84	\$40.84
Project Engineer/ Resident Engineer 1	\$32.79	\$32.79
Senior Technician 2	\$47.04	\$47.04
Engineer 3	\$28.90	\$28.90
Engineer 2	\$28.50	\$28.50
Engineer 1	\$26.85	\$26.85
Resident Technician / Senior Technician 1	\$33.82	\$33.82
Technician 2	\$23.35	\$23.35
Technician 1 / Engineering Intern	\$15.00	\$15.00
Sr. Admin. Management Consultant	\$46.00	\$46.00
Administrative Associate 3	\$25.49	\$25.49
Administrative Associate 2	\$20.00	\$20.00
Administrative Associate 1	\$15.36	\$15.36
Intern	\$15.00	\$15.00
		\$0.00
		\$0.00

**COST PLUS FIXED FEE
COST ESTIMATE OF CONSULTANT SERVICES**

DF-824-039

REV 12/04
04/25/18

FIRM
PSB
PRIME/SUPPLEMENT

ESI Consultants Ltd.
IL 53 at Peotone Rd.
Prime

OVERHEAD RATE
COMPLEXITY FACTOR

1.4149
0

DATE

FF= 14.5%*(DL+R(DL)+OH(DL)+IHDC)

DBE DROP BOX	ITEM	MANHOURS (A)	PAYROLL (B)	OVERHEAD & FRINGE BENF (C)	IN-HOUSE DIRECT COSTS (D)	FIXED FEE (E)	Outside Direct Costs (F)	SERVICES BY OTHERS (G)	DBE TOTAL (H)	TOTAL (B-G)	% OF GRAND TOTAL
	Pre-Construction	115	4,450.86	6,297.53		1,558.52				12,306.91	6.16%
	Construction	1138	43,058.79	60,923.89		15,077.49	10,400.00			129,460.17	64.75%
	Post-Construction	323	12,023.00	17,011.34		4,209.98				33,244.32	16.63%
	Rebidding Phase	50	2,864.00	4,052.27						6,916.27	3.46%
	Program Management (Ruettiger/Tonelli)							6,000.00		6,000.00	3.00%
	Material Testing							12,000.00		12,000.00	6.00%
	Subconsultant DL					0.00				0.00	0.00%
	TOTALS	1626	62,396.66	88,285.03	0.00	20,845.98	10,400.00	18,000.00	0.00	199,927.67	100.00%

AVERAGE HOURLY PROJECT RATES

FIRM ESI Consultants Ltd.
PSB IL 53 at Peotone Rd.
PRIME/SUPPLEMENT Prime

DATE 04/25/18

SHEET 1 OF 5

PAYROLL CLASSIFICATION	AVG HOURLY RATES	TOTAL PROJECT RATES			Pre-Construction			Construction			Post-Construction			Rebidding Phase			Program Management (Ru		
		Hours	% Part.	Wgtd Avg	Hours	% Part.	Wgtd Avg	Hours	% Part.	Wgtd Avg	Hours	% Part.	Wgtd Avg	Hours	% Part.	Wgtd Avg	Hours	% Part.	Wgtd Avg
President / Principal **	70.00	12	0.74%	0.52	2	1.74%	0.93	6	0.53%	0.28	2	0.62%	0.43	2	4.00%	2.80			
Vice President / Director**	70.00	0			0			0			0								
Senior Manager / Senior Consul	53.63	0			0			0			0								
Senior Structural Project Manag	65.05	0			0			0			0								
Senior Project Manager	63.50	90	5.53%	3.51	16	13.91%	8.83	48	4.22%	2.68	2	0.62%	0.39	24	48.00%	30.48			
Structural Project Manager	37.00	0			0			0			0								
Project Manager / Project Mana	46.34	0			0			0			0								
Senior Resident Engineer	50.00	764	46.93%	23.46	40	34.78%	17.39	540	47.45%	23.73	160	49.54%	24.77	24	48.00%	24.00			
Resident Engineer 2	40.84	0			0			0			0								
Project Engineer/ Resident Engi	32.79	0			0			0			0								
Senior Technician 2	47.04	0			0			0			0								
Engineer 3	28.90	0			0			0			0								
Engineer 2	28.50	0			0			0			0								
Engineer 1	26.85	0			0			0			0								
Resident Technician / Senior Te	33.82	0			0			0			0								
Technician 2	23.35	756	46.44%	10.84	56	48.70%	11.37	540	47.45%	11.08	160	49.54%	11.57						
Technician 1 / Engineering Inter	15.00	0			0			0			0								
Sr. Admin. Management Consul	46.00	0			0			0			0								
Administrative Associate 3	25.49	0			0			0			0								
Administrative Associate 2	20.00	6	0.37%	0.07	1	0.87%	0.17	4	0.35%	0.07	1	0.31%	0.06						
Administrative Associate 1	15.36	0			0			0			0								
		0																	
		0																	
		0																	
		0																	
		0																	
		0																	
TOTALS		1628	100%	\$38.41	115	100.00%	\$38.70	1138	100%	\$37.84	323	101%	\$37.22	50	100%	\$57.28	0	0%	\$0.00

Municipality Wilmington	L O C A L A G E N C Y	 Illinois Department of Transportation Preliminary/Construction Engineering Services Agreement For Motor Fuel Tax Funds Supplement #1	C O N S U L T A N T	Name ESI Consultants, Ltd
Township				Address 1979 North Mill Street Suite 100
County Will				City Naperville
Section				State IL

THIS AGREEMENT is made and entered into this _____ day of July, 2018 between the above Local Agency (LA) and Consultant (ENGINEER) and covers certain professional engineering services in connection with the improvement of the above PROJECT. Motor Fuel Tax Funds, allotted to the LA by the State of Illinois under the general supervision of the State Department of Transportation, hereinafter called the "DEPARTMENT", will be used entirely or in part to finance ENGINEERING services as described under AGREEMENT PROVISIONS.

WHEREVER IN THIS AGREEMENT or attached exhibits the following terms are used, they shall be interpreted to mean:

Regional Engineer	Deputy Director Division of Highways, Regional Engineer, Department of Transportation
Resident Construction Supervisor	Authorized representative of the LA in immediate charge of the engineering details of the PROJECT
Contractor	Company or Companies to which the construction contract was awarded

Section Description

Name Illinois Route 53 Route _____ Length _____ miles Structure No. _____
Termini at Wilmington-Peotone Road

Description
This project involves the construction engineering services for the intersection improvement of Illinois Route 53 at Wilmington-Peotone Road. Improvements include widening for additional channelization and traffic signal improvements.

Agreement Provisions

The Engineer Agrees,

1. To perform or be responsible for the performance of the following engineering services for the LA in connection with the proposed improvement herein before described, and checked below:
 - a. Make such detailed surveys as are necessary for the preparation of detailed roadway plans.
 - b. Make stream and flood plain hydraulic surveys and gather high water data and flood histories for the preparation of detailed bridge plans.
 - c. Make or cause to be made such soil surveys or subsurface investigations including borings and soil profiles and analyses thereof as may be required to furnish sufficient data for the design of the proposed improvement. Such investigations are to be made in accordance with the current requirements of the DEPARTMENT.
 - d. Make or cause to be made such traffic studies and counts and special intersection studies as may be required to furnish sufficient data for the design of the proposed improvement.

- e. Prepare Army Corps of Engineers Permit, Division of Water Resources Permit, Bridge waterway sketch and/or Channel Change sketch, Utility plan and locations and Railroad Crossing work agreements.
- f. Prepare Preliminary Bridge Design and Hydraulic Report, (including economic analysis of bridge or culvert types) and high water effects on roadway overflows and bridge approaches.

NOTE Four copies to be submitted to the Regional Engineer

- g. Make complete general and detailed plans, special provisions, proposals and estimates of cost and furnish the LA with five (5) copies of the plans, special provisions, proposals and estimates. Additional copies of any or all documents, if required shall be furnished to the LA by the ENGINEER at his actual cost for reproduction.
- h. Furnish the LA with survey and drafts in quadruplicate of all necessary right-of-way dedications, construction easements and borrow pit and channel change agreements including prints of the corresponding plats and staking as required.
- i. Assist the LA in the receipt and evaluation of proposals and the awarding of the construction contract.
- j. Furnish or cause to be furnished for Quality Assurance purposes:
 - (1) Proportioning and testing of concrete mixtures in accordance with the "Manual of Instructions for Concrete Proportioning and Testing" issued by the Bureau of Materials and Physical Research, of the DEPARTMENT and promptly submit reports on forms prepared by said Bureau.
 - (2) Proportioning and testing of bituminous mixtures (including extracting test) in accordance with the "Manual of Instructions for Bituminous Proportioning and Testing" issued by the Bureau of Materials and Physical Research, of the DEPARTMENT, and promptly submit reports on forms prepared by said Bureau.
 - (3) All compaction tests as required by the specifications and report promptly the same on forms prepared by the Bureau of Materials and Physical Research.
 - (4) Quality and sieve analyses on local aggregates to see that they comply with the specifications contained in the contract.
 - (5) Inspection of all materials when inspection is not provided at the sources by the Bureau of Materials and Physical Research, of the DEPARTMENT and submit inspection reports to the LA and the DEPARTMENT in accordance with the policies of the said DEPARTMENT.
- k. Furnish or cause to be furnished
 - (1) A resident construction supervisor, inspectors, and other technical personnel to perform the following work: (The number of such inspectors and other technical personnel required shall be subject to the approval of the LA.)
 - a. Continuous observation of the work and the contractor's operations for compliance with the plans and specifications as construction proceeds, but the ENGINEER does not guarantee the performance of the contract by the contractor.
 - b. Establishment and setting of lines and grades.
 - c. Maintain a daily record of the contractor's activities throughout construction including sufficient information to permit verification of the nature and cost of changes in plans and authorized extra work.
 - d. Supervision of inspectors, proportioning engineers and other technical personnel and the taking and submitting of material samples.
 - e. Revision of contract drawings to reflect as built conditions.
 - f. Preparation and submission to the LA in the required form and number of copies, all partial and final payment estimates, change orders, records and reports required by the LA and the DEPARTMENT.

NOTE: *When Federal funds are used for construction and the ENGINEER or the ENGINEER's assigned staff is named as resident construction supervisor, the ENGINEER is required to be prequalified with the STATE in Construction Inspection. The onsite resident construction supervisor and project inspectors shall possess valid Documentation of Contract Quantities certification.*

2. That all reports, plans, plats and special provisions to be furnished by the ENGINEER pursuant to this agreement will be in accordance with the current standard specifications and policies of the DEPARTMENT, it being understood that all such reports, plats, plans and drafts shall before being finally accepted, be subject to approval by the LA and the said DEPARTMENT.
3. To attend conferences at any reasonable time when requested to do so by the LA or representatives of the DEPARTMENT.
4. In the event plans, surveys or construction staking are found to be in error during the construction of the PROJECT and revisions of the plans or survey or construction staking corrections are necessary, the ENGINEER agrees that he will perform such work without expense to the LA, even though final payment has been received by him. He shall give immediate attention to these changes so there will be a minimum delay to the contractor.
5. The basic survey notes and sketches, charts, computations and other data prepared or obtained by the ENGINEER pursuant to this agreement will be made available upon request to the LA or the DEPARTMENT without cost and without restriction or limitations as to their use.
6. To make such changes in working plans, including all necessary preliminary surveys and investigations, as may be required after the award of the construction contract and during the construction of the improvement.
7. That all plans and other documents furnished by the ENGINEER pursuant to the AGREEMENT will be endorsed by him and will show his professional seal where such is required by law.
8. To submit, upon request by the LA or the DEPARTMENT a list of the personnel and the equipment he/she proposes to use in fulfilling the requirements of this AGREEMENT.

The LA Agrees,

1. To pay the Engineer as compensation for all services performed as stipulated in paragraphs 1a, 1g, 1i, 1j and 1k, 2, 3, 5 and 6 in accordance with one of the following methods indicated by a check mark:
 - a A sum of money equal to actual hourly rates of principals and employees times a direct labor multiplier of 2.8 (which includes overhead and profit) for the actual hours worked on the project plus any direct project expenses such as travel and equipment and sub-consultants for a total not to exceed \$199,927.67.
 - b A sum of money equal to the percentage of the awarded contract cost for the proposed improvement as approved by the DEPARTMENT based on the following schedule:

Schedule for Percentages Based on Awarded Contract Cost

Awarded Cost Under \$50,000	Percentage Fees	(see note)
		%
		%
		%
		%
		%

Note: Not necessarily a percentage. Could use per diem, cost-plus or lump sum.

2. To pay for services stipulated in paragraphs 1b, 1c, 1d, 1e, 1f and 1h of THE ENGINEER AGREES at the hourly rates stipulated below for personnel assigned to this PROJECT as payment in full to the ENGINEER for the actual time spent in providing these services the hourly rates to include profit, overhead, readiness to serve, insurance, social security and retirement deductions. Traveling and other out-of-pocket expenses will be reimbursed to the ENGINEER at his actual cost. Subject to the approval of the LA, the ENGINEER may sublet all or part of the services provided under paragraphs 1b, 1c, 1d, 1e, 1f, 1j and 1k of THE ENGINEER AGREES. If the ENGINEER sublets all or a part of this work, the LA will pay the cost to the ENGINEER plus a five (5) percent service charge. "Cost to ENGINEER" to be verified by furnishing the LA and the DEPARTMENT copies of invoices from the party doing the work. The classifications of the employees used in the work should be consistent with the employee classifications for the services performed. If the personnel of the firm including the Principal Engineer perform routine services that should normally be performed by lesser-salaried personnel, the wage rate billed for such services shall be commensurate with the work performed.

Grade Classification of Employee	Hourly Rate
Principal Engineer	_____
Resident Construction Supervisor	_____
Chief of Party	_____
Instrument Man	_____
Rodmen	_____
Inspectors	_____
_____	_____
_____	_____
_____	_____
_____	_____

The hourly rates itemized above shall be effective the date the parties, hereunto entering this AGREEMENT, have affixed their hands and seals and shall remain in effect until 12/31/2018. In event the services of the ENGINEER extend beyond 12/31/2018, the hourly rates will be adjusted yearly by addendum to this AGREEMENT to compensate for increases or decreases in the salary structure of the ENGINEER that are in effect at that time.

3. That payments due the ENGINEER for services rendered pursuant to this AGREEMENT will be made as soon as practicable after the services have been performed, in accordance with the following schedule:
 - a. Upon completion of detailed plans, special provisions, proposals and estimate of cost - being the work required by paragraphs 1a through 1g under THE ENGINEER AGREES - to the satisfaction of the LA and their approval by the DEPARTMENT, 90 percent of the total fee based on the above fee schedule and the approved estimate of cost.
 - b. Upon award of the contract for the improvement by the LA and its approval by the DEPARTMENT, 100 percent of the total fee (excluding any fees paragraphs 1j and 1k of the ENGINEER AGREES), based on the above fee schedule and the awarded contract cost, less any previous payment.
 - c. Upon completion of the construction of the improvement, 90 percent of the fee due for services stipulated in paragraphs 1j and 1k.
 - d. Upon completion of all final reports required by the LA and the DEPARTMENT and acceptance of the improvement by the DEPARTMENT, 100 percent of the total fees due under this AGREEMENT, less any amounts previously paid.

By mutual agreement, partial payments, not to exceed 90 percent of the amount earned, may be made from time to time as the work progresses.

4. That should the improvements be abandoned at any time after the ENGINEER has performed any part of the services provided for in paragraphs 1a and 1g, and prior to the completion of such services the LA shall reimburse the ENGINEER for his actual costs plus 180% percent incurred up to the time he is notified in writing of such abandonment "actual cost" being defined as material costs plus actual payrolls, insurance, social security and retirement deductions. Traveling and other out-of-pocket expenses will be reimbursed to the ENGINEER at his actual cost.
5. That should the LA require changes in any of the detailed plans, specifications or estimates (except for those required pursuant to paragraph 4 of THE ENGINEER AGREES) after they have been approved by the DEPARTMENT, the LA will pay the ENGINEER for such changes on the basis of actual cost plus 180% percent to cover profit, overhead and readiness to serve - "actual cost" being defined as in paragraph 4 above. It is understood that "changes" as used in this paragraph shall in no way relieve the ENGINEER of his responsibility to prepare a complete and adequate set of plans.
6. That should the LA extend completion of the improvement beyond the time limit given in the contract, the LA will pay the ENGINEER, in addition to the fees provided herein, his actual cost incurred beyond such time limit - "actual cost" being defined as in paragraph 4 above.
7. To submit approved forms BC 775 and BC 776 with this AGREEMENT when federal funds are used for construction.

It is Mutually Agreed,

1. That any difference between the ENGINEER and the LA concerning the interpretation of the provisions of this AGREEMENT shall be referred to a committee of disinterested parties consisting of one member appointed by the

ENGINEER one member appointed by the LA and a third member appointed by the two other members for disposition and that the committee's decision shall be final.

2. This AGREEMENT may be terminated by the LA upon giving notice in writing to the ENGINEER at his last known post office address. Upon such termination, the ENGINEER shall cause to be delivered to the LA all drawings, specifications, partial and completed estimates and data if any from traffic studies and soil survey and subsurface investigations with the understanding that all such material becomes the property of the LA. The ENGINEER shall be paid for any services completed and any services partially completed in accordance with Section 4 of THE LA AGREES.
3. That if the contract for construction has not been awarded one year after the acceptance of the plans by the LA and their approval by the DEPARTMENT, the LA will pay the ENGINEER the balance of the engineering fee due to make 100 percent of the total fees due under the AGREEMENT, based on the estimate of cost as prepared by the ENGINEER and approved by the LA and the DEPARTMENT.
4. That the ENGINEER warrants that he/she has not employed or retained any company or person, other than a bona fide employee working solely for the ENGINEER, to solicit or secure this contract and that he/she has not paid or agreed to pay any company or person, other than a bona fide employee working solely for the ENGINEER, any fee, commission, percentage, brokerage fee, gifts or any other consideration contingent upon or resulting from the award or making of this contract. For breach or violation of this warranty the LA shall have the right to annul this contract without liability.

IN WITNESS WHEREOF, the parties have caused this AGREEMENT to be executed in quadruplicate counterparts, each of which shall be considered as an original by their duly authorized offices.

Executed by the LA:

_____ of the
City of Wilmington
(Municipality/Township/County)

ATTEST:

State of Illinois, acting by and through its

By _____,

_____ ,

Clerk

By _____

(Seal)

Title:

Executed by the ENGINEER:

ATTEST:

By _____

Title:

Title:

Approved

Date
Department of Transportation

Regional Engineer



ESI Consultants, Ltd.
Excellence, Service, Integrity

Mayor Roy Strong
City of Wilmington
1165 S. Water Street
Wilmington, IL 60481

July 1, 2018

Re: Proposal for Supplemental Professional Engineering Services
Modifications Related to Historic Route 66
N River Road at Illinois Route 53
Wilmington, Illinois

Dear Mayor Strong:

This supplement addresses the additional services related to additional reports and revisions required as a result of the historic Route 66 updated considerations. The original intersection design proceeded based on prior approvals and directions on this and adjacent intersections. During the design, IDOT requested additional studies, reports and coordination related historic Route 66 which were not included in the original scope of services.

Pursuant your direction, ESI Consultants, Ltd. (ESI) has prepared the attached proposal for supplemental engineering to add these reports and revise the plans accordingly. Included is a discussion of the various design elements that remain to be performed. ESI requests a fee of **\$87,680** for the additional engineering services related to additional reports, coordination and plan revisions for the North River Road at Illinois Route 53 Intersection Improvement Project. It is our opinion that the City of Wilmington may request that IDOT allow the City to utilize a portion of the remaining Economic Development Program (EDP) credits as needed to fund this additional effort. Alternatively, this would also be eligible for MFT funding or other City funding.

Please note that based on our estimates there are sufficient funds remaining in the EDP credits to cover the costs of this supplemental Design work as well as the Construction and Construction Engineering cost. Final approvals of this proposal is subject to IDOT review and funding approvals.

We believe can have these plans and related permitting completed in time for Spring 2019 construction is we are authorized to proceed soon.

If you should find this proposal acceptable, please process this as quickly as practical for approval and execution in order to meet the desired schedule goals.

Please feel free to call me directly at (630) 420-1700 or contact me by e-mail at mreznicek@esiltd.com if you have any questions or comments.

Sincerely,

ESI CONSULTANTS, LTD.

Mark Reznicek, P.E.
Senior Project Manager

Joseph M. Chiczewski, P.E.
President

Project Understanding

ESI Consultants (ESI) had originally prepared Plans, Specifications and Estimates for the intersection of South Arsenal Road at IL 53 to include auxiliary lanes along IL 53, a 5 lane cross section on S Arsenal Rd (including dual left turns and single right turn lane as well as 2 received lanes on S Arsenal Road) and new traffic signals. After the plans were completed the City determined that the small parcel of land required for this full improvement would be too costly and too lengthy of a process to acquire so the City Administrator approved supplemental fees and directed ESI to revise the plans to reduce the footprint and eliminate the need for any land acquisition while still installing the permanent traffic signals. The reduced scope was referred to as Phase 1 of the intersection improvement and generally involved the reconstruction of the three existing lanes along S Arsenal Road.

This Phase 1 design revision was completed in 2016 and the construction is nearing completion at the time of this supplement. For the full improvement benefits, Phase 2 will require a new set of plans to be completed to further widen S Arsenal Road for the full turn lanes and receiving lanes at the intersection. Phase 2 is also necessary for the drainage improvements to be more effective. Additionally the City of Wilmington has requested the addition of a multi-use path to extend from N River Road to the north side of South Arsenal Road to improve the region's transportation options (allowing for bicycles and pedestrians) and connectivity (note with the addition of a path the right of way may have a slight adjust for the intersection crossing).

This Supplement assumes that the ESR and the IDS, previously approved by IDOT, will not require revisions as the area has already been reviewed for the full build-out conditions.

The following is a brief discussion of the notable design elements as they relate to these revisions

The original design called for the extension of the 4 lane divided highway along IL 53 thru the intersection of N River Road. Based on the previously approved intersection improvements just north of this project location (IL 53 at S Arsenal Road) and the previously approved intersection improvements just south of this location (Peotone Road at IL 53) as well as the construction project completed by IDOT in 2013 at this same location the design progressed based on the 4 lane divided highway with dual left turn lanes concept. During the review process IDOT adjusted how it approaches the historic issues related to Historic Route 66 (this section of IL 53 is the Historic Route 66). The required the following additions and revisions:

- 1) Section 106 Historic Preservation Issues:
 - a. Revised traffic study to address directional traffic and to address changes in the design year
 - b. Alternatives comparison: address various alternatives intersection designs to determine the least impact to Historic route 66 based on the updated traffic study
 - c. Revise IDS to address alternatives evaluation. This required additional revisions further based on additional IDOT feedback to coordinate with IDOT's IL 53 long range planning study which was begun subsequent to this project.
- 2) Revise Pre-final plans (including drainage) in order to address the revised IDS and reduced footprint.
- 3) Additional coordination with IDOT local office and central office, FHWA, and SHPO related to historic issues, changes in lane configuration and IDOT's separate long range IL 53 plans.
- 4) Additional Administration related to the additional design and extended schedule
- 5) Elimination of ROW and a reduction in the geotechnical needs based on the revised layout.

In addition to the aforementioned revisions as the project developed ESI re-allocated some of the survey work from outside consultant to in-house (zero net cost increase)

Exclusions

This agreement does not include services for:

- Construction Engineering Services

Schedule

Upon approval of this agreement the remaining effort will be completed within approximately 4 months to allow construction to be completed in 2018.

Compensation

ESI Consultants, Ltd (ESI) proposes to provide the necessary professional consulting services for a supplemental lump sum fee of **\$87,680**.

The estimated hours and fees to complete each task detailed by assignment are included on the attached spreadsheets (Exhibit A). For progress billing purposes this will be billed based on the approximate percent of completion as determined by the engineer.

END

Municipality City of Wilmington	L O C A L A G E N C Y	 Illinois Department of Transportation Preliminary Engineering Services Agreement For Motor Fuel Tax Funds Supplement #1	C O N S U L T A N T	Name ESI Consultants, Ltd.
Township				Address 1979 N. Mill Street
County Will				City Naperville
Section 15-00050-00-CH				State Illinois

THIS AGREEMENT is made and entered into this _____ day of _____, 2018 between the above Local Agency (LA) and Consultant (ENGINEER) and covers certain professional engineering services in connection with the improvement of the above SECTION. Motor Fuel Tax Funds, allotted to the LA by the State of Illinois under the general supervision of the State Department of Transportation, hereinafter called the "DEPARTMENT", will be used entirely or in part to finance ENGINEERING services as described under AGREEMENT PROVISIONS.

Section Description

Name IL Route 53

Route IL Route 53 Length 0.85 Mi. 4,500 FT (Structure No. N/A)

Termini at North River Road Intersection

Description:

Supplement one to add Historic Rte 66 preservation studies and reports, revise plans and IDS to address these historic issues including additional agency coordination

Agreement Provisions

The Engineer Agrees,

1. To perform or be responsible for the performance of the following engineering services for the LA, in connection with the proposed improvements herein before described, and checked below:
 - a. Make such detailed surveys as are necessary for the preparation of detailed roadway plans
 - b. Make stream and flood plain hydraulic surveys and gather high water data, and flood histories for the preparation of detailed bridge plans.
 - c. Make or cause to be made such soil surveys or subsurface investigations including borings and soil profiles and analyses thereof as may be required to furnish sufficient data for the design of the proposed improvement. Such investigations are to be made in accordance with the current requirements of the DEPARTMENT.
 - d. Make or cause to be made such traffic studies and counts and special intersection studies as may be required to furnish sufficient data for the design of the proposed improvement.
 - e. Prepare Army Corps of Engineers Permit, Department of Natural Resources-Office of Water Resources Permit, Bridge waterway sketch, and/or Channel Change sketch, Utility plan and locations, and Railroad Crossing work agreements.
 - f. Prepare Preliminary Bridge design and Hydraulic Report, (including economic analysis of bridge or culvert types) and high water effects on roadway overflows and bridge approaches.
 - g. Make complete general and detailed plans, special provisions, proposals and estimates of cost and furnish the LA with five (5) copies of the plans, special provisions, proposals and estimates. Additional copies of any or all documents, if required, shall be furnished to the LA by the ENGINEER at his actual cost for reproduction.
 - h. Furnish the LA with survey and drafts in quadruplicate of all necessary right-of-way dedications, construction easement and borrow pit and channel change agreements including prints of the corresponding plats and staking as required.

Note: Four copies to be submitted to the Regional Engineer

- i. Assist the LA in the tabulation and interpretation of the contractors' proposals
 - j. Prepare the necessary additional environmental documents and revisions to prior approved documents in accordance with the procedures adopted by the DEPARTMENT's Bureau of Local Roads & Streets.
 - k. Prepare the Project Development Report when required by the DEPARTMENT.
- (2) That all reports, plans, plats and special provisions to be furnished by the ENGINEER pursuant to the AGREEMENT, will be in accordance with current standard specifications and policies of the DEPARTMENT. It is being understood that all such reports, plats, plans and drafts shall, before being finally accepted, be subject to approval by the LA and the DEPARTMENT.
 - (3) To attend up to 3 conferences at any reasonable time when requested to do so by representatives of the LA or the Department.
 - (4) In the event plans or surveys are found to be in error during construction of the SECTION and revisions of the plans or survey corrections are necessary, the ENGINEER agrees that he will perform such work without expense to the LA, even though final payment has been received by him. He shall give immediate attention to these changes so there will be a minimum delay to the Contractor.
 - (5) That basic survey notes and sketches, charts, computations and other data prepared or obtained by the Engineer pursuant to this AGREEMENT will be made available, upon request, to the LA or the DEPARTMENT without cost and without restriction or limitations as to their use.
 - (6) That all plans and other documents furnished by the ENGINEER pursuant to this AGREEMENT will be endorsed by him and will show his professional seal where such is required by law.

The LA Agrees,

1. To pay the ENGINEER as compensation for all services performed as stipulated in paragraphs 1b, 1f, & 1k in accordance with one of the following methods indicated by a check mark:
 - a. A sum of money equal to _____ percent of the awarded contract cost of the proposed improvement as approved by the DEPARTMENT.
 - b. A sum of money equal to the percent of the awarded contract cost for the proposed improvement as approved by the DEPARTMENT based on the following schedule:

Schedule for Percentages Based on Awarded Contract Cost

Awarded Cost	Percentage Fees	(see note)
Under \$50,000	_____	%
	_____	%
	_____	%
	_____	%
	_____	%

Note: Not necessarily a percentage. Could use per diem, cost-plus or lump sum

2. To pay for services stipulated in paragraphs 1a, 1c, 1d, 1e, 1f, 1g, 1h, 1i, 1j, 1k, 2, 3, 5 and 6 of the ENGINEER AGREES a lump sum fee of \$87,680. This fee has been developed based on the attached Cost Estimate of Consultant Services (see Attachment A) utilizing the ENGINEER's IDOT provisional overhead rate. Subject to the approval of the LA, the ENGINEER may sublet all or part of the services provided under the paragraph 1a, 1b, 1c, 1d, 1e, 1f, 1h, 1j & 1k.
3. That payments due the ENGINEER for services rendered in accordance with this AGREEMENT will be made as soon as practicable after the services have been performed in accordance with the following schedule:
 - a) **For progressive payments** – Upon receipt of monthly invoices from the ENGINEER and the approval thereof by the LA, monthly payments for the work performed shall be due and payable to the ENGINEER, such payments to be equal to the value of the partially completed work minus all previous partial payments made to the ENGINEER.

- b) **Final Payment** – Upon approval of the work by the LA but not later than 60 days after the work is completed and reports have been made and accepted by the LA and STATE, a sum of money equal to the basic fee as determined in this AGREEMENT less the total of the amounts of partial payments previously paid to the ENGINEER shall be due and payable to the ENGINEER.
4. That, should the improvement be abandoned at any time after the ENGINEER has performed any part of the services provided for in paragraphs 1a, through 1h and prior to the completion of such services, the LA shall reimburse the ENGINEER for his actual costs plus 10 percent incurred up to the time he is notified in writing of such abandonment -“actual cost” being defined as in paragraph 2 of THE LA AGREES
5. That, should the LA require changes in any of the detailed plans, specifications or estimates except for those required pursuant to paragraph 4 of THE ENGINEER AGREES, after they have been approved by the DEPARTMENT, the LA will pay the ENGINEER for such changes on the basis of actual cost plus 10 percent to cover profit, overhead and readiness to serve -“actual cost” being defined as in paragraph 2 of THE LA AGREES. It is understood that “changes” as used in this paragraph shall in no way relieve the ENGINEER of his responsibility to prepare a complete and adequate set of plans and specifications.

It is Mutually Agreed,

1. That any difference between the ENGINEER and the LA concerning their interpretation of the provisions of this Agreement shall be referred to a committee of disinterested parties consisting of one member appointed by the ENGINEER, one member appointed by the LA and a third member appointed by the two other members for disposition and that the committee’s decision shall be final.
2. This AGREEMENT may be terminated by the LA upon giving notice in writing to the ENGINEER at his last known post office address. Upon such termination, the ENGINEER shall cause to be delivered to the LA all surveys, permits, agreements, preliminary bridge design & hydraulic report, drawings, specifications, partial and completed estimates and data, if any from traffic studies and soil survey and subsurface investigations with the understanding that all such material becomes the property of the LA. The ENGINEER shall be paid for any services completed and any services partially completed in accordance with Section 4 of THE LA AGREES.
3. That if the contract for construction has not been awarded one year after the acceptance of the plans by the LA and their approval by the DEPARTMENT, the LA will pay the ENGINEER the balance of the engineering fee due to make 100 percent of the total fees due under this AGREEMENT, based on the estimate of cost as prepared by the ENGINEER and approved by the LA and the DEPARTMENT.
4. That the ENGINEER warrants that he/she has not employed or retained any company or person, other than a bona fide employee working solely for the ENGINEER, to solicit or secure this contract, and that he/she has not paid or agreed to pay any company or person, other than a bona fide employee working solely for the ENGINEER, any fee, commission, percentage, brokerage fee, gifts or any other consideration, contingent upon or resulting from the award or making of this contract. For Breach or violation of this warranty the LA shall have the right to annul this contract without liability.

IN WITNESS WHEREOF, the parties have caused the AGREEMENT to be executed in quadruplicate counterparts, each of which shall be considered as an original by their duly authorized officers.

Executed by the LA:

City of Wilmington of the
(Municipality/Township/County)

ATTEST: State of Illinois, acting by and through its

By _____

Clerk By _____

(Seal)

Title _____

Executed by the ENGINEER:

ESI Consultants, Ltd.

ATTEST: _____

By _____ By _____

Title _____ Title _____

Approved

Date
Department of Transportation

Regional Engineer



**Illinois Department
of Transportation**

**Cost Estimate of
Consultant Services**

(Direct Labor Multiple)
04/25/18

Firm ESI Consultants, Ltd.
 Route _____
 Section _____
 County Will
 Job No. _____
 PTB & Item N Rver Road at IL 53-SUPPLEMENT

Date _____

Overhead Rate _____

Complexity Factor _____

0

DBE DROP BOX	ITEM	MANHOURS (A)	PAYROLL (B)	(2.80+R) TIMES PAYROLL (C)	DIRECT COSTS (D)	SERVICES BY OTHERS (E)	DBE TOTAL (C+D+E)	TOTAL (C+D+E)	% OF GRAND TOTAL
	Section 106 / Historic Preservation	280	12,943.30	36,241.25				36,241.25	41.33%
	Revise Pre-final engineering	276	12,236.42	34,261.97				34,261.97	39.08%
	Supplemental Coordination	124	7,386.47	20,682.11				20,682.11	23.59%
	Adminstration	50	2,462.54	6,895.11				6,895.11	7.86%
	Program Mngmnt (Ruettiger/Tonelli)					2,600.00		2,600.00	2.97%
	reduction in geotech and land acq					-13,000.00		-13,000.00	-14.83%
	TOTALS	730	35,028.73	98,080.44	0.00	-10,400.00	0.00	87,680.44	100.00%

DBE 0.00%



Average Hourly Project Rates

Route _____
 Section _____
 County Will
 Job No. _____
 PTB/Item N Rver Road at IL 53-SUPPLEMENT

Consultant ESI Consultants, Ltd.

Date 04/25/18

Sheet 1 OF 1

Payroll Classification	Avg Hourly Rates	Total Project Rates			Section 106 / Historic Preserva			Revise Pre-final engineering			Supplemental Coordination			Adminstration			Program Mngmnt (Ruettiger/To		
		Hours	% Part.	Wgtd Avg	Hours	% Part.	Wgtd Avg	Hours	% Part.	Wgtd Avg	Hours	% Part.	Wgtd Avg	Hours	% Part.	Wgtd Avg	Hours	% Part.	Wgtd Avg
President / Principal **	\$70.00	128	17.53%	12.27	48	17.14%	12.00	24	8.70%	6.09	40	32.26%	22.58	16	32.00%	22.40			
Vice President / Director**	\$70.00	0																	
Senior Manager / Senior Cons	\$54.57	0																	
Senior Structural Project Mand	\$66.19	0																	
Senior Project Manager	\$63.10	124	16.99%	10.72	30	10.71%	6.76	24	8.70%	5.49	60	48.39%	30.53	10	20.00%	12.62			
Structural Project Manager	\$37.65	0																	
Project Manager / Project Man	\$47.15	88	12.05%	5.68	28	10.00%	4.72	60	21.74%	10.25									
Senior Resident Engineer	\$49.01	0																	
Resident Engineer 2	\$41.55	0																	
Project Engineer/ Resident En	\$33.36	180	24.66%	8.23	96	34.29%	11.44	48	17.39%	5.80	24	19.35%	6.46	12	24.00%	8.01			
Senior Technician 2	\$47.86	108	14.79%	7.08	48	17.14%	8.20	60	21.74%	10.40									
Engineer 3	\$29.41	0																	
Engineer 2	\$29.00	90	12.33%	3.58	30	10.71%	3.11	60	21.74%	6.30									
Engineer 1	\$27.32	0																	
Resident Technician / Senior T	\$34.41	0																	
Technician 2	\$23.76	0																	
Technician 1 / Engineering Int	\$15.26	0																	
Sr. Admin. Management Cons	\$46.81	0																	
Administrative Associate 3	\$25.94	12	1.64%	0.43										12	24.00%	6.22			
Administrative Associate 2	\$20.35	0																	
Administrative Associate 1	\$15.63	0																	
		0																	
		0																	
		0																	
		0																	
		0																	
		0																	
		0																	
		0																	
		0																	
TOTALS		730	100%	\$47.98	280	100%	\$46.23	276	100%	\$44.33	124	100%	\$59.57	50	100%	\$49.25	0	0%	\$0.00



Payroll Escalation Table
Fixed Raises
New Formula

FIRM NAME ESI Consultants, Ltd.
PRIME/SUPPLEMENT Prime

DATE 04/25/18
PTB NO. N Rver Road at IL 53-SUPPLEMENT

CONTRACT TERM 12 MONTHS
START DATE 11/1/2017
RAISE DATE 4/1/2018

OVERHEAD RATE _____
COMPLEXITY FACTOR _____
% OF RAISE 3.00%

ESCALATION PER YEAR

11/1/2017 - 4/1/2018

4/2/2018 - 11/1/2018

$\frac{5}{12}$

$\frac{7}{12}$

= 41.67%
= 1.0175

60.08%

1.75%

The total escalation for this project would be:



**Illinois Department
of Transportation**

Payroll Rates

FIRM NAME ESI Consultants, Ltd. **DATE** 04/25/18
PRIME/SUPPLEMENT Prime
PTB NO. N Rver Road at IL 53-SUPPLEMENT

ESCALATION FACTOR 1.75%

CLASSIFICATION	CURRENT RATE	ESCALATED RATE
President / Principal **	\$70.00	\$70.00
Vice President / Director**	\$70.00	\$70.00
Senior Manager / Senior Consultant	\$53.63	\$54.57
Senior Structural Project Manager	\$65.05	\$66.19
Senior Project Manager	\$62.01	\$63.10
Structural Project Manager	\$37.00	\$37.65
Project Manager / Project Manager Consultant	\$46.34	\$47.15
Senior Resident Engineer	\$48.17	\$49.01
Resident Engineer 2	\$40.84	\$41.55
Project Engineer/ Resident Engineer 1	\$32.79	\$33.36
Senior Technician 2	\$47.04	\$47.86
Engineer 3	\$28.90	\$29.41
Engineer 2	\$28.50	\$29.00
Engineer 1	\$26.85	\$27.32
Resident Technician / Senior Technician 1	\$33.82	\$34.41
Technician 2	\$23.35	\$23.76
Technician 1 / Engineering Intern	\$15.00	\$15.26
Sr. Admin. Management Consultant	\$46.00	\$46.81
Administrative Associate 3	\$25.49	\$25.94
Administrative Associate 2	\$20.00	\$20.35
Administrative Associate 1	\$15.36	\$15.63
		\$0.00
		\$0.00
		\$0.00
		\$0.00
		\$0.00
		\$0.00
		\$0.00
		\$0.00
		\$0.00
		\$0.00
		\$0.00

\$0.00
\$0.00
\$0.00

CRACK SEALING PROGRAM



SealMaster®
Pavement Products & Equipment
www.sealmaster.net

SealMaster®
Pavement Products & Equipment

PO Box 2277
Sandusky, OH 44870



Pavement Maintenance Products From the Name You Trust.

SealMaster® is the only national supplier of pavement maintenance supplies and equipment. Whatever pavement issues you have, we have the right products and know the right people to fix them.

- Pavement Sealers
- Crack Fillers
- Traffic Paints
- Equipment & Parts
- Contractor Referrals
- Sealer Additives
- Repair Products
- Concrete Products
- Tools & Accessories

**You have pavement questions?
We have your answers.**

**Call (800) 395-7325 to locate a
SealMaster® near you.**

SealMaster®
Pavement Products & Equipment

Do You Need to Extend the Life of Your Asphalt Pavement During a Challenging Budget Year?

CRACK SEALING PROGRAM

Crack sealing slows the rate of deterioration which can postpone the next scheduled asphalt overlay.



The Strategic Highway Research Programs (SHRP) Long Term Pavement Performance (LTPP) studies indicate that **instituting a preventative maintenance program** including cracksealing can extend the life of asphalt 5 to 10 years. Cracks allow water to penetrate the asphalt, softening the stone base and leading to alligator cracking/spider webbing, pot holes, and other forms of degradation. Cracks left over the winter can grow quickly due to snow plowing and the freeze/thaw cycle. Asphalt patching often doesn't last and can cost several times what timely crack-sealing costs. In the end, the useful life of the surface is shortened, forcing the premature and costly replacement of the surface.

“Crack sealing and filling are imperative preventative maintenance tools.”

-The Federal Highway Administration Manual of Practice (FHWA Report Number FHWS-RD-99-147)

Offering Cost-Effective Crack Filling Options to Extend the Life of Your Asphalt Pavement.

SealMaster® Program Details

SEALMASTER® WILL:

- Deliver 4,800 lbs. of rubberized crack sealant - enough to fill 50,000 lineal feet of cracks.
- Deliver CrackPro model 125 DA (specs listed) - machine includes air compressor for crack cleaning.
- Provide equipment training with safety focus.



- Offer quantity discounts

All materials & equipment proudly made in the USA!

You will need a 3-person crew minimum, 3/4 ton truck or larger with Pintle hitch, and 2-4 days to apply the material.

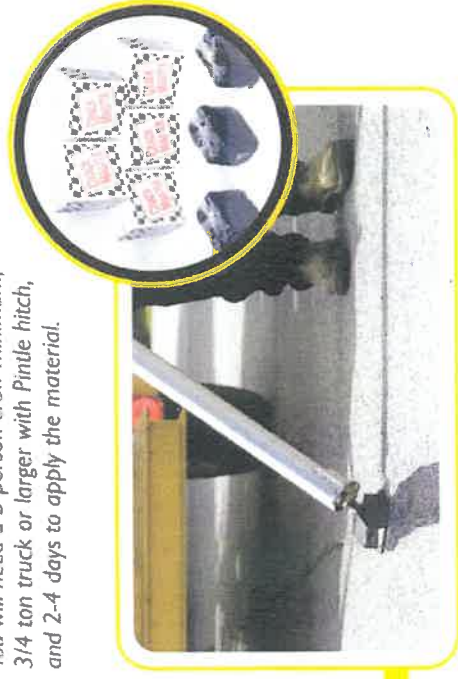

Crack Pro® 125 Heated Hose Machine



FEATURES:

- Liquid Cooled Kubota Diesel Engine
- Easy-to-use Digital Control Center
- State-of-the-Art Burner System w/Auto Shut-Off
- Anti-Splash Material Loading Hatch

SPECIFICATIONS:

Tank Capacity	125 Gallons
Heat Transfer Oil	12 gallon capacity
Maximum BTU Input	372,000 BTU
Construction	Oil jacketed tank
Temperature Control	Automatic Electronic
Tank Opening	16" x 24" no splash material loading
Insulation	1 1/2" High Temperature Ceramic
Agitation	Full Sweep, Hydraulically Driven, Reversible
Material Pump	2" Steel Gear, Reversible
Heating System	Bottom-fired, forced-air diesel fuel
Suspension	Torsion type axle with 5-lug tubeless tire
Application Hose	3/4" x 18' electric hose
Heated Hose	Eliminates need to flush out hose for cleanup

For SealMaster® Equipment Sales Call: (800) 395-7311

Estimate

375 Roma Jean Pkwy
 Streamwood, IL 60107
 630-372-8300
 630-372-2600 Fax

Date	Estimate #
5/11/2018	5583

Name / Address
Cash Sale - Wood Dale Wilmington City 815-405-2231 kewenson@wilmington-il.com

Ship To
Cash Sale - Wood Dale

			Terms	Project
Qty	Item	Description	Cost	Total
1	E2745HH	Equipment, Crack Pro 125 Melter/Applicator w/ Heated Hose	44,620.00	44,620.00T
			Subtotal	\$44,620.00
			Sales Tax (0.0%)	\$0.00
			Total	\$44,620.00

Kankakee Truck Equipment, Inc.
785 Eastgate Industrial Parkway
Kankakee, IL 60901
Phone: 815-939-2541 Fax: 815-939-1701
7/30/2018

City of Wilmington
114 N. Main
Wilmington, IL 60481

"Demonstrator"

We are pleased to make the following reference:

- 2017 Ford F550 XL
- 4x4 SD regular cab 60'' CA
- Diesel Automatic
- Red in color
- See attached specs
- Galioin 133 U -9'
- 9' in length
- 18'' fixed sides
- 10 ga. Sides and ends
- 3/16 AR 450 floor
- Body of Stainless Steel
- 24'' quick release tail gate
- Mailhot telescopic DA hoist
- Integral cab shield
- Force PTO and direct mount pump
- Force VT 15 tank/valve combo
- Force Electric spreader controller 3100 EX
- Hydraulic lines to rear for spreader
- Western IUTPP9.0 plow
- Western plow mount and wiring for plow
- Hydraulic lines to front of vehicle for plow
- Controls for Dump ,plow lift and plow angle
- Whelen LED lighting system Model DOT 3202B
- Spreader light , Back alarm
- Rear mud flaps and front SS fenders
- 15 ton pintle hook on ½ plate
- Truck will be available for September delivery
- All above equipment mounted and painted

Total price for one complete unit : \$83,488.00

We thank you for the opportunity to be of service. If there are any questions regarding this Proposal or to place an order for any equipment described, please contact us at your convenience.

Sincerely,

Dean Kleinert
President



Rod Baker Ford Sls Inc
16101 S. Lincoln Highway, Plainfield, Illinois, 605865183
Office: 815-436-5681

Customer Proposal

Prepared for:

Dean Kleinert
Kankakee Truck Equipment

Prepared by:

Dan Saxen
Office: 815-556-3200
Email: dansaxen@rodbakerford.com

Date: 07/20/2018

Vehicle: 2019 F-550 Chassis XL
4x4 SD Regular Cab 145" WB DRW

Quote ID: KKT19F-550





Dean Kleinert
Kankakee Truck Equipment

Re: Vehicle Proposal

Dear Dean,

Thank you very much for your interest in acquiring a vehicle from our dealership. We concur that your interest is well deserved. We hope that an outstanding product lineup and our dedication to customer service will enhance your ownership experience should you decide to buy a vehicle from us.

Attached, please find additional information that I hope will assist you in making a more informed decision. Please feel free to contact me at any time as I would truly appreciate the opportunity to be of service to you.

Sincerely,

Dan Saxen
Commercial/Fleet Sales Manager
815-556-3200
dansaxen@rodbakerford.com



Rod Baker Ford Sls Inc
16101 S. Lincoln Highway, Plainfield, Illinois,
605865183
Office: 815-436-5681

2019 F-550 Chassis, SD Regular Cab
4x4 SD Regular Cab 145" WB DRW XL(F5H)
Price Level: 925 Quote ID: KKT19F-550

Table of Contents

Description	Page
Cover Page	1
Cover Letter	2
Table of Contents	3
Pricing - Single Vehicle	4
Warranty - Selected	5
Selected Options	6
Performance Tests	9



Rod Baker Ford Sls Inc
 16101 S. Lincoln Highway, Plainfield, Illinois,
 605865183
 Office: 815-436-5681

2019 F-550 Chassis, SD Regular Cab
 4x4 SD Regular Cab 145" WB DRW XL(F5H)
 Price Level: 925 Quote ID: KKT19F-550

Pricing - Single Vehicle

		MSRP
<i>Vehicle Pricing</i>		
Base Vehicle Price		\$42,040.00
Options & Colors		\$14,065.00
Upfitting		\$0.00
Destination Charge		\$1,495.00
Subtotal		\$57,600.00
<i>Pre-Tax Adjustments</i>		
Code	Description	
D.F.	Doc Fee	\$175.94
RBF	Municipal Discount	-\$9,718.00
<small>Truck MUST be sold by 10/4/2018 for discount to be valid</small>		
Subtotal		\$48,057.94
<i>Post-Tax Adjustments</i>		
Code	Description	
Title	Title Fee	\$95.00
plates	New Municipal Plate	\$8.00
Total		\$48,160.94

Customer Signature _____

Acceptance Date _____

Prices and content availability as shown are subject to change and should be treated as estimates only. Actual base vehicle, package and option pricing may vary from this estimate because of special local pricing, availability or pricing adjustments not reflected in the dealer's computer system. See salesperson for the most current information.

Prepared for: Dean Kleinert, Kankakee Truck Equipment
 By: Dan Saxen Date: 07/20/2018



Warranty - Selected Equipment & Specs

Warranty

Basic

Distance	36000 miles	Months	36 months
----------	-------------	--------	-----------

Powertrain

Distance	60000 miles	Months	60 months
----------	-------------	--------	-----------

Corrosion Perforation

Distance	Unlimited miles	Months	60 months
----------	-----------------	--------	-----------

Roadside Assistance

Distance .	60000 miles	Months	60 months
------------	-------------	--------	-----------

Diesel Engine

Distance	100000 miles	Months	60 months
----------	--------------	--------	-----------

Prices and content availability as shown are subject to change and should be treated as estimates only. Actual base vehicle, package and option pricing may vary from this estimate because of special local pricing, availability or pricing adjustments not reflected in the dealer's computer system. See salesperson for the most current information.

Prepared for: Dean Kleinert, Kankakee Truck Equipment
 By: Dan Saxen Date: 07/20/2018



Selected Options

Description	MSRP
Base Vehicle	
Base Vehicle Price (F5H)	\$42,040.00
Packages	
Order Code 660A	N/C
<i>Includes:</i> - Wheels: 19.5" Argent Painted Steel - Includes manual locking hubs. - HD Vinyl 40/20/40 Split Bench Seat - Includes center armrest, cupholder, storage and driver's side manual lumbar.	
Powertrain	
Engine: 6.7L 4V OHV Power Stroke V8 Turbo Diesel B20	\$9,010.00
<i>Includes Diesel Exhaust Fluid (DEF) tank, Intelligent Oil-Life Monitor, manual push-button engine-exhaust braking and split-shaft calibration compatibility.</i> <i>Includes:</i> - Dual 78-AH 750 CCA Batteries	
Transmission: TorqShift 6-Speed Automatic	N/C
(6R140). Includes SelectShift.	
Limited Slip w/4.88 Axle Ratio	\$360.00
GVWR: 19,500 lb Payload Plus Upgrade Package	\$1,155.00
<i>Includes upgraded frame, rear-axle and low deflection/high capacity springs. Increases max RGAWR to 14, 706. Note: See Order Guide Supplemental Reference for further details on GVWR.</i>	
Wheels & Tires	
Tires: 225/70Rx19.5G BSW Traction (TGB)	\$215.00
<i>Includes 4 traction tires on the rear and 2 traction tires on the front. Not recommended for over the road applications; could incur irregular front tire wear and/or NVH. Optional spare is 225/70Rx19.5G BSW traction.</i>	
Wheels: 19.5" Argent Painted Steel	Included
<i>Includes manual locking hubs.</i>	
Seats & Seat Trim	
HD Vinyl 40/20/40 Split Bench Seat	Included
<i>Includes center armrest, cupholder, storage and driver's side manual lumbar.</i>	
Other Options	
Monotone Paint Application	STD
145" Wheelbase	STD
XL Value Package	\$1,000.00

Prices and content availability as shown are subject to change and should be treated as estimates only. Actual base vehicle, package and option pricing may vary from this estimate because of special local pricing, availability or pricing adjustments not reflected in the dealer's computer system. See salesperson for the most current information.



Selected Options (cont'd)

Description	MSRP
<p><i>Includes:</i></p> <ul style="list-style-type: none"> - 4.2" Center-Stack Screen - Radio: AM/FM Stereo/MP3 Player <p><i>Includes 4 speakers.</i></p> <ul style="list-style-type: none"> - SYNC Communications & Entertainment System <p><i>Includes enhanced voice recognition with 911 Assist, 4.2" LCD center stack screen, AppLink, 1 smart-charging USB port and steering wheel audio controls.</i></p> <ul style="list-style-type: none"> - XL Decor Group - Chrome Front Bumper - Steering Wheel-Mounted Cruise Control 	
Power Equipment Group	\$915.00
<p><i>Deletes passenger side lock cylinder. Includes upgraded door-trim panel.</i></p> <p><i>Includes:</i></p> <ul style="list-style-type: none"> - Accessory Delay - Advanced Security Pack <p><i>Includes SecuriLock Passive Anti-Theft System (PATS) and inclination/intrusion sensors.</i></p> <ul style="list-style-type: none"> - Trailer Tow Mirrors w/Power Heated Glass <p><i>Includes manual telescoping, heated convex spotter mirror and integrated clearance lamps/turn signals.</i></p> <ul style="list-style-type: none"> - MyKey <p><i>Includes owner controls feature.</i></p> <ul style="list-style-type: none"> - Power Front Side Windows <p><i>Includes 1-touch up/down driver/passenger window.</i></p> <ul style="list-style-type: none"> - Power Locks - Remote Keyless Entry 	
Snow Plow Prep Package	\$185.00
<p><i>Includes pre-selected springs (see Order Guide Supplemental Reference for springs/FGAWR of specific vehicle configurations). Note 1: Restrictions apply; see Supplemental Reference or Body Builders Layout Book for details. Note 2: Also allows for the attachment of a winch.</i></p> <p><i>Includes:</i></p> <ul style="list-style-type: none"> - Dual Alternators (Total 332-Amps) 	
Engine Block Heater	\$100.00
6-Ton Hydraulic Jack	\$55.00
Transmission Power Take-Off Provision	\$280.00
<i>Includes transmission mounted live drive and stationary mode PTO.</i>	
Dual Alternators (Total 332-Amps)	Included
26.5 Gallon Mid Ship Fuel Tank	\$125.00
Trailer Brake Controller	\$270.00
<i>Includes smart trailer tow connector. Verified to be compatible with electronic actuated drum brakes only.</i>	
Platform Running Boards	\$320.00
110V/400W Outlet	\$75.00
<i>Includes 1 in-dash mounted outlet.</i>	
Radio: AM/FM Stereo/MP3 Player	Included
<p><i>Includes 4 speakers.</i></p> <p><i>Includes:</i></p> <ul style="list-style-type: none"> - SYNC Communications & Entertainment System <p><i>Includes enhanced voice recognition with 911 Assist, 4.2" LCD center stack screen, AppLink, 1 smart-charging USB port and steering wheel audio controls.</i></p>	

Fleet Options

Steering Wheel-Mounted Cruise Control	Included
XL Decor Group	Included

Prices and content availability as shown are subject to change and should be treated as estimates only. Actual base vehicle, package and option pricing may vary from this estimate because of special local pricing, availability or pricing adjustments not reflected in the dealer's computer system. See salesperson for the most current information.



Rod Baker Ford Sls Inc
 16101 S. Lincoln Highway, Plainfield, Illinois,
 605865183
 Office: 815-436-5681

2019 F-550 Chassis, SD Regular Cab
 4x4 SD Regular Cab 145" WB DRW XL(F5H)
 Price Level: 925 Quote ID: KKT19F-550

Selected Options (cont'd)

Description	MSRP
<i>Includes:</i> - Chrome Front Bumper	
Emissions	
50-State Emissions System	STD
Interior Colors	
Medium Earth Gray	N/C
Primary Colors	
Race Red	N/C
SUBTOTAL	\$56,105.00
Destination Charge	\$1,495.00
TOTAL	\$57,600.00

Prices and content availability as shown are subject to change and should be treated as estimates only. Actual base vehicle, package and option pricing may vary from this estimate because of special local pricing, availability or pricing adjustments not reflected in the dealer's computer system. See salesperson for the most current information.

Prepared for: Dean Kleinert, Kankakee Truck Equipment
 By: Dan Saxen Date: 07/20/2018



Performance

Performance predictions in this report represent an estimate of vehicle performance based on standard operating conditions. Variations in customer equipment, load configuration, ambient conditions, and/or operator driving techniques can cause significant variations in vehicle performance. These values are not representative of results that may be shown in actual dynamometer tests. This report should therefore be used as a guide for comparative vehicle performance.

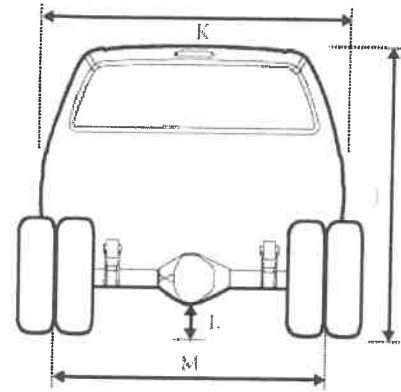
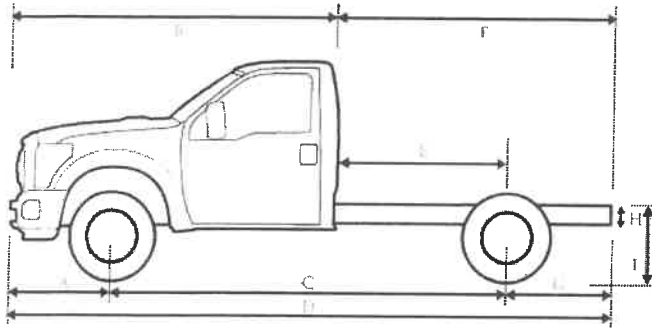

Dimensions

A	Front of Bumper to Front Axle	38.30 in.
B	Front Bumper to Back of Cab (BBC)	123.70 in.
C	Wheelbase (WB)	145.00 in.
D	Overall Length (OAL)	230.70 in.
E	Back of Cab to Rear Axle (CA)	60.00 in.
F	Back of Cab to End of Frame	107.20 in.
G	Rear Axle to End of Frame (AF)	47.20 in.
H	Frame Section Height	N/A
I	Rear Frame Height Unloaded	35.10 in.
I	Rear Frame Height Loaded	28.60 in.
J	Cab Height	81.50 in.
K	Body Width	80.00 in.
L	Maximum Ground Clearance	N/A
L	Minimum Ground Clearance	8.20 in.
M	Front Tread	74.80 in.
M	Rear Tread	74.00 in.

Prices and content availability as shown are subject to change and should be treated as estimates only. Actual base vehicle, package and option pricing may vary from this estimate because of special local pricing, availability or pricing adjustments not reflected in the dealer's computer system. See salesperson for the most current information.



Performance (cont'd)

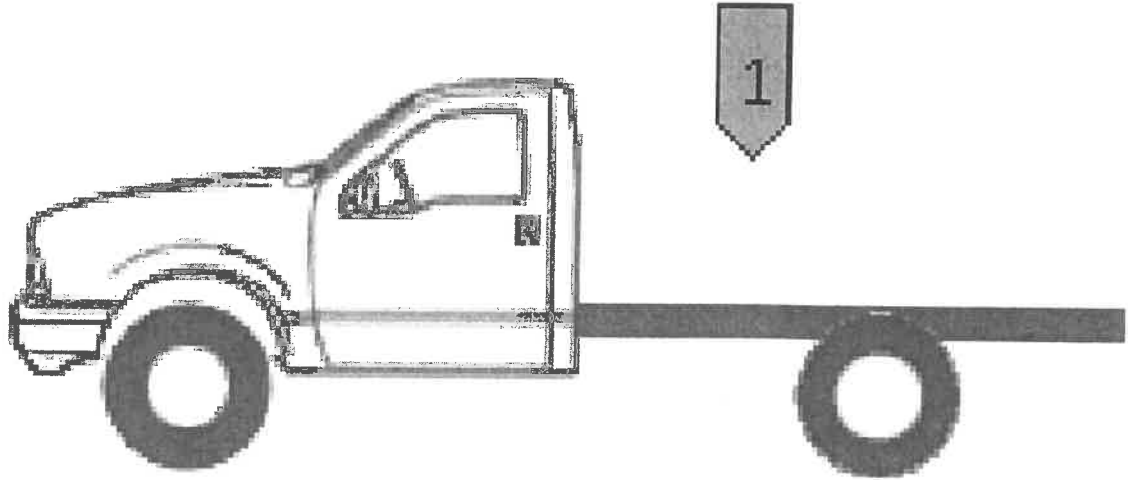

Weight

GVW	Front Axle	Rear Axle	Totals
Chassis	4,660 lbs	3,108 lbs	7,768 lbs
Body	0 lbs	0 lbs	0 lbs
Occupants Weight	300 lbs	150 lbs	450 lbs
Fuel	-65 lbs	-33 lbs	-98 lbs
1 Max Payload - (Max Payload)	2,105 lbs	9,275 lbs	11,380 lbs
TOTAL	7,000 lbs	12,500 lbs	19,500 lbs

Ratings	Front Axle	Rear Axle	GVWR
GAWR	7,000 lbs	14,706 lbs	19,500 lbs
Wheels/Tires	7,500 lbs	15,000 lbs	
Suspension	7,000 lbs	15,000 lbs	
Axle	7,000 lbs	14,706 lbs	
Legal Axle Limit	0 lbs	0 lbs	

Prices and content availability as shown are subject to change and should be treated as estimates only. Actual base vehicle, package and option pricing may vary from this estimate because of special local pricing, availability or pricing adjustments not reflected in the dealer's computer system. See salesperson for the most current information.



Performance (cont'd)

Start, Grade and Speed

Start	Ratio	Desired	Calculated
Start grade capability in 1st gear	3.97	15.00 %	42.71 %
Start grade capability in reverse	3.13	15.00 %	33.62 %
Grade	Ratio	Desired	Calculated
Maximum grade in 4th gear	1.15	3.00 %	13.00 %
Maximum grade in 5th gear	0.86	3.00 %	9.71 %
Maximum grade in 6th gear	0.67	3.00 %	7.63 %
Speed		Desired	Calculated
Top Speed (level grade)		75 mph	88 mph
<i>To meet your requirement you need a maximum axle ratio of 5.74</i>			
Top Speed on 3.0% grade		55 mph	
<i>To meet your requirement you need a maximum of 122 hp</i>			
Cruise Speed		60 mph	65 mph
Engine RPM at desired cruise speed			2,121 rpm

Variables in Use

Rear axle ratio:	4.88/4.88	Governed RPM:	3,120 rpm
Tire size:	225/70R19.5 (645 rev/mile)	Frontal Area:	40.28 Sq.Ft.
Gross Vehicle Weight (GVW):	19,500 lbs	Cruising RPM	2,300 rpm
Clutch engagement torque:	375 ft.lbs.	Worst road surface	Typical Highway
Torque conversion ratio:	1.90	Final Drive Ratio:	0.67
Peak engine torque:	750 ft.lbs.	Drag Coefficient	0.80
Engine Power:	330 hp @ 2,600 rpm		

Prices and content availability as shown are subject to change and should be treated as estimates only. Actual base vehicle, package and option pricing may vary from this estimate because of special local pricing, availability or pricing adjustments not reflected in the dealer's computer system. See salesperson for the most current information.



Performance (cont'd)

Shift Chart

Shift Chart displays mathematical geared speed.

Diesel engines use Governed RPM for shift points.

Gas engines use Peak Torque RPM for shift points.

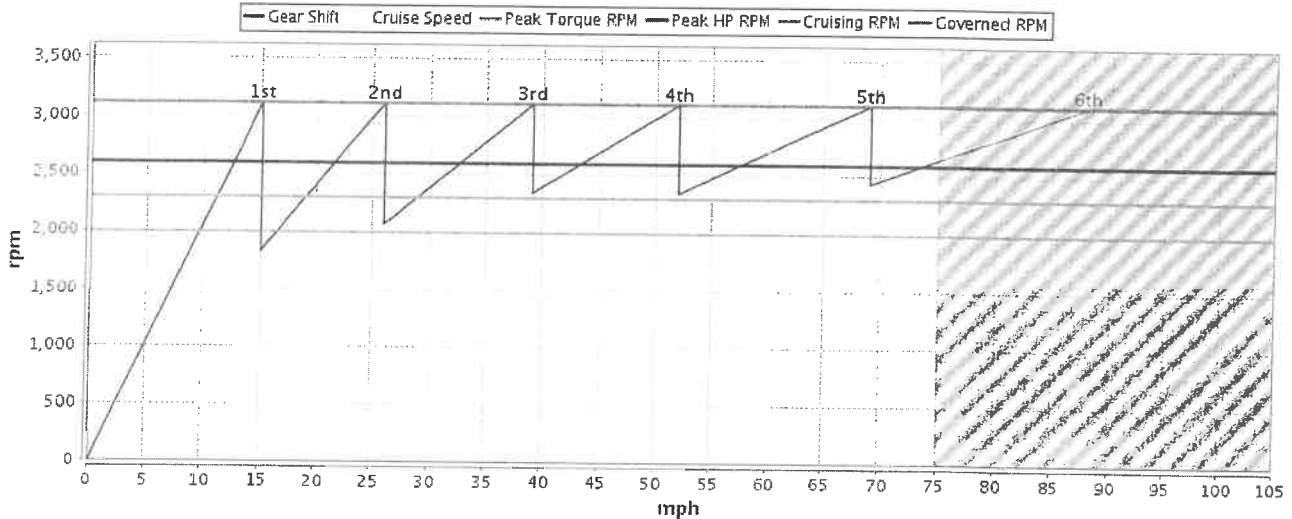

Turning Radius

Turning Radius

21.25 ft

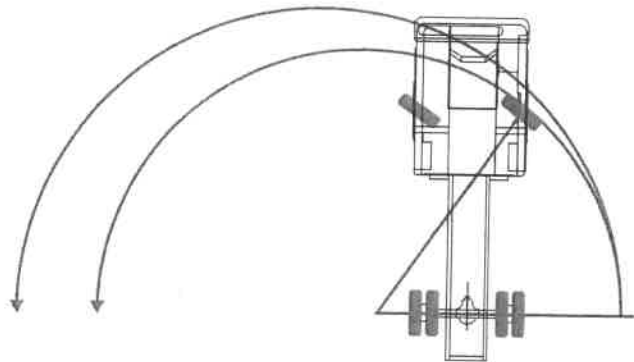

Prices and content availability as shown are subject to change and should be treated as estimates only. Actual base vehicle, package and option pricing may vary from this estimate because of special local pricing, availability or pricing adjustments not reflected in the dealer's computer system. See salesperson for the most current information.

Prepared for: Dean Kleinert, Kankakee Truck Equipment
 By: Dan Saxen Date: 07/20/2018

Prepared For:
CITY OF WILMINGTON
Ken Ewenson
1165 S Water St.
Wilmington, IL 60481-1633
(815)476 - 2175
Reference ID: N/A

Presented By:
RUSH TRK CTR OF N IL
Bill Cavanaugh
11816 S IL RTE 47
HUNTLEY IL 60142 -
(847)669-5700

Thank you for the opportunity to provide you with the following quotation on a new International truck. I am sure the following detailed specification will meet your operational requirements, and I look forward to serving your business needs.

Model Profile
2019 7400 SFA 6X4 (SF525)

APPLICATION:	Front Plow and Wing with Spreader
MISSION:	Requested GVWR: 56000. Calc. GVWR: 56000 Calc. Start / Grade Ability: 23.93% / 1.84% @ 55 MPH Calc. Geared Speed: 63.5 MPH
DIMENSION:	Wheelbase: 179.00, CA: 104.00, Axle to Frame: 63.00
ENGINE, DIESEL:	{Cummins L9 330} EPA 2017, 330HP @ 2000 RPM, 1000 lb-ft Torque @ 1400 RPM, 2200 RPM Governed Speed, 330 Peak HP (Max)
TRANSMISSION, AUTOMATIC:	{Allison 3000 RDS} 5th Generation Controls, Close Ratio, 6-Speed with Double Overdrive, with PTO Provision, Less Retarder, Includes Oil Level Sensor, On/Off Highway
CLUTCH:	Omit Item (Clutch & Control)
AXLE, FRONT NON-DRIVING:	{Meritor MFS-16-143A} Wide Track, I-Beam Type, 16,000-lb Capacity
AXLE, REAR, TANDEM:	{Meritor MT-40-14X-4DFR-P} Single Reduction, 40,000-lb Capacity, with Lube Oil Pump, w/. 433"(11mm) Wall Housing Thickness, R Wheel Ends Gear Ratio: 6.43
CAB:	Conventional
TIRE, FRONT:	(2) 315/80R22.5 Load Range L G751 MSA (GOODYEAR), 484 rev/mile, 68 MPH, All-Position
TIRE, REAR:	(8) 11R22.5 Load Range G G622 RSD (GOODYEAR), 497 rev/mile, 75 MPH, Drive
SUSPENSION, REAR, TANDEM:	{Hendrickson HMX-400-52} Walking Beam Type 52" Axle Spacing; 40,000-lb Capacity, with Rubber End Bushings, Transverse Torque Rods, Less Shock Absorbers
PAINT:	Cab schematic 100GM Location 1: 2303, Red (Std) Chassis schematic N/A

<u>Code</u>	<u>Description</u>
SF52500	Base Chassis, Model 7400 SFA 6X4 with 179.00 Wheelbase, 104.00 CA, and 63.00 Axle to Frame.
1CAJ	FRAME RAILS Heat Treated Alloy Steel (120,000 PSI Yield); 10.866" x 3.622" x 0.433" (276.0mm x 92.0mm x 11.1mm); 456.0" (11582mm) Maximum OAL
1LLA	BUMPER, FRONT Steel, Swept Back <u>Includes</u> : BUMPER, FRONT Powder Coated Gray (Argent) Color
1WDS	FRAME EXTENSION, FRONT Integral; 20" In Front of Grille
1WGB	WHEELBASE RANGE 177" (450cm) Through and Including 226" (575cm)
2ARU	AXLE, FRONT NON-DRIVING {Meritor MFS-16-143A} Wide Track, I-Beam Type, 16,000-lb Capacity <u>Notes</u> : The following features should be considered when calculating Front GAWR: Front Axles; Front Suspension; Brake System; Brakes, Front Air Cam; Wheels; Tires.
3708	SHOCK ABSORBERS, FRONT
3770	SPRINGS, FRONT AUXILIARY Rubber
3ACP	SUSPENSION, FRONT, SPRING Multileaf, Shackle Type; 16,000-lb Capacity; Less Shock Absorbers <u>Includes</u> : SPRING PINS Rubber Bushings, Maintenance-Free <u>Notes</u> : The following features should be considered when calculating Front GAWR: Front Axles; Front Suspension; Brake System; Brakes, Front Air Cam; Wheels; Tires.
4091	BRAKE SYSTEM, AIR Dual System for Straight Truck Applications <u>Includes</u> : BRAKE LINES Color and Size Coded Nylon : DRAIN VALVE Twist-Type : GAUGE, AIR PRESSURE (2) Air 1 and Air 2 Gauges; Located in Instrument Cluster : PARKING BRAKE CONTROL Yellow Knob, Located on Instrument Panel : PARKING BRAKE VALVE For Truck : QUICK RELEASE VALVE On Rear Axle for Spring Brake Release: 1 for 4x2, 2 for 6x4 : SLACK ADJUSTERS, FRONT Automatic (with Air Cam Brakes) : SLACK ADJUSTERS, REAR Automatic (with Air Cam Brakes) : SPRING BRAKE MODULATOR VALVE R-7 for 4x2, SR-7 with relay valve for 6x4/8x6 <u>Notes</u> : Rear Axle is Limited to 46,000-lb GAWR with Code 04091 BRAKE SYSTEM, AIR and Standard Rear Air Cam Brakes Regardless of Axle /Suspension Ordered.
4193	BRAKES, FRONT, AIR CAM 16.5" x 6", Includes 24 SqIn Long Stroke Brake Chambers <u>Notes</u> : The following features should be considered when calculating Front GAWR: Front Axles; Front Suspension; Brake System; Brakes, Front Air Cam; Wheels; Tires.
4619	TRAILER CONNECTIONS Four-Wheel, with Hand Control Valve and Tractor Protection Valve, for Straight Truck
4722	DRAIN VALVE {Bendix DV-2} Automatic, with Heater, for Air Tank <u>Includes</u> : DRAIN VALVE Mounted in Wet Tank
4AZA	AIR BRAKE ABS {Bendix AntiLock Brake System} Full Vehicle Wheel Control System (4-Channel)

<u>Code</u>	<u>Description</u>
4EBT	AIR DRYER {Bendix AD-IP} with Heater <u>Includes</u> : AIR DRYER LOCATION Inside Left Rail, Back of Cab
4EXU	BRAKE CHAMBERS, REAR AXLE {Bendix EverSure} 30/30 Spring Brake
4EXV	BRAKE CHAMBERS, FRONT AXLE {Bendix} 24 SqIn
4LAA	SLACK ADJUSTERS, FRONT {Haldex} Automatic
4LGA	SLACK ADJUSTERS, REAR {Haldex} Automatic
4NDB	BRAKES, REAR, AIR CAM S-Cam; 16.5" x 7.0"; Includes 30/30 Sq.In. Long Stroke Brake Chamber and Spring Actuated Parking Brake <u>Notes</u> : The following features should be considered when calculating Rear GAWR: Rear Axles; Rear Suspension; Brake System; Brakes, Rear Air Cam; Brake Shoes, Rear; Special Rating, GAWR; Wheels; Tires.
4SPA	AIR COMPRESSOR {Cummins} 18.7 CFM Capacity
5710	STEERING COLUMN Tilting and Telescoping
5CAL	STEERING WHEEL 2-Spoke, 18" Dia., Black
5PTB	STEERING GEAR (2) {Sheppard M100/M80} Dual Power
6DDA	DRIVESHAFT SYSTEM {Dana Spicer} SPL170XL with SPL170XL Interaxle Shaft in lieu of 1710 Driveshaft with 1710 Interaxle Shaft
7BEU	AFTERTREATMENT COVER Aluminum
7BKS	EXHAUST SYSTEM Single Horizontal Aftertreatment Device, Frame Mounted Right Side Under Cab; for Single Vertical Tail Pipe, Frame Mounted Right Side Back of Cab
7WAZ	TAIL PIPE (1) Turnback Type, Non-Bright, for Single Exhaust
7WCM	EXHAUST HEIGHT 8' 10"
7WDN	MUFFLER/TAIL PIPE GUARD (1) Non-Bright Aluminum
8000	ELECTRICAL SYSTEM 12-Volt, Standard Equipment <u>Includes</u> : DATA LINK CONNECTOR For Vehicle Programming and Diagnostics In Cab : HAZARD SWITCH Push On/Push Off, Located on Top of Steering Column Cover : HEADLIGHT DIMMER SWITCH Integral with Turn Signal Lever : HEADLIGHTS (2) Halogen, Round, with Chrome Plated Bezels : JUMP START STUD Located on Positive Terminal of Outermost Battery : PARKING LIGHT Integral with Front Turn Signal and Rear Tail Light : STARTER SWITCH Electric, Key Operated : STOP, TURN, TAIL & B/U LIGHTS Dual, Rear, Combination with Reflector : TURN SIGNAL SWITCH Self-Cancelling for Trucks, Manual Cancelling for Tractors, with Lane Change Feature : WINDSHIELD WIPER SWITCH 2-Speed with Wash and Intermittent Feature (5 Pre-Set Delays), Integral with Turn Signal Lever : WINDSHIELD WIPERS Single Motor, Electric, Cowl Mounted : WIRING, CHASSIS Color Coded and Continuously Numbered
8518	CIGAR LIGHTER Includes Ash Cup
8GXD	ALTERNATOR {Leece-Neville AVI160P2013} Brush Type; 12 Volt 160 Amp. Capacity, Pad Mount, with Remote Sense

<u>Code</u>	<u>Description</u>
8HAB	BODY BUILDER WIRING Back of Standard or Sleeper Cab at Left Frame or Under Extended or Crew Cab at Left Frame; Includes Sealed Connectors for Tail/Amber Turn/Marker/ Backup/Accessory Power/Ground and Sealed Connector for Stop/Turn
8MSH	BATTERY SYSTEM {Fleetrite} Maintenance-Free, (4) 12-Volt 2640CCA Total
8RCB	CB RADIO Accommodation Package; Header Mounted; Feeds From Accessory Side of Ignition Switch; Includes Power Source and Two Antenna Bases with Wiring
	<u>Notes</u> : NOT INCLUDED: Antenna
8RMD	RADIO AM/FM/WB/Clock/3MM Auxiliary Input, with Multiple Speakers
8THJ	AUXILIARY HARNESS 3.0' for Auxiliary Front Head Lights and Turn Signals for Front Plow Applications
8TMG	TRAILER CONNECTION SOCKET 7-Way; Mounted at Rear of Frame, Wired for Turn Signals Combined with Stop, Compatible with Trailers That Use Combined Stop, Tail, Turn Lamps
8VAY	HORN, ELECTRIC Disc Style
8VUJ	BATTERY BOX Steel with Plastic Cover, 18" Wide, 2, 3, or 4 Battery Capacity, Mounted Right Side Back of Cab
8WBW	JUMP START STUD Remote Mounted
	<u>Includes</u> : JUMP START STUD Mounted to Battery Box
8WCL	HORN, AIR Black, Single Trumpet, Air Solenoid Operated
8WPH	CLEARANCE/MARKER LIGHTS (5) {Truck Lite} Amber LED Lights, Flush Mounted on Cab or Sunshade
8WTL	STARTING MOTOR {Delco Remy 39MT} 12 Volt; Gear Reduced, with Thermal Over-Crank Protection
8WWJ	INDICATOR, LOW COOLANT LEVEL with Audible Alarm
8XAH	CIRCUIT BREAKERS Manual-Reset (Main Panel) SAE Type III with Trip Indicators, Replaces All Fuses
8XGT	TURN SIGNALS, FRONT Includes LED Side Turn Lights Mounted on Fender
9585	FENDER EXTENSIONS Rubber
9HBM	GRILLE Stationary, Chrome
9WBC	FRONT END Tilting, Fiberglass, with Three Piece Construction; for WorkStar/HV
10060	PAINT SCHEMATIC, PT-1 Single Color, Design 100
	<u>Includes</u> : PAINT SCHEMATIC ID LETTERS "GM"
10761	PAINT TYPE Base Coat/Clear Coat, 1-2 Tone
11001	CLUTCH Omit Item (Clutch & Control)
12703	ANTI-FREEZE Red, Extended Life Coolant; To -40 Degrees F/ -40 Degrees C, Freeze Protection
12849	BLOCK HEATER, ENGINE 120V/1000W, for Cummins ISB/B6.7/ISL/L9 Engines
12EHV	ENGINE, DIESEL {Cummins L9 330} EPA 2017, 330HP @ 2000 RPM, 1000 lb-ft Torque @ 1400 RPM, 2200 RPM Governed Speed, 330 Peak HP (Max)
12THT	FAN DRIVE {Horton Drivemaster} Direct Drive Type, Two Speed with Residual Torque Device for Disengaged Fan Speed
	<u>Includes</u> : FAN Nylon

<u>Code</u>	<u>Description</u>
12UWY	RADIATOR Cross Flow, Series System; 1228 SqIn Aluminum Radiator Core and 1167 SqIn Charge Air Cooler <u>Includes</u> : DEAERATION SYSTEM with Surge Tank : HOSE CLAMPS, RADIATOR HOSES Gates Shrink Band Type; Thermoplastic Coolant Hose Clamps : RADIATOR HOSES Premium, Rubber
12VAL	AIR CLEANER Dual Element, with Integral Snow Valve and In-Cab Control <u>Includes</u> : GAUGE, AIR CLEANER RESTRICTION Air Cleaner Mounted
12VGN	FEDERAL EMISSIONS {Cummins L9} EPA, OBD and GHG Certified for Calendar Year 2018
12VXT	THROTTLE, HAND CONTROL Engine Speed Control; Electronic, Stationary, Variable Speed; Mounted on Steering Wheel
12WZE	EMISSION COMPLIANCE Federal, Does Not Comply with California Clean Air Idle Regulations
12XAT	ENGINE CONTROL, REMOTE MOUNTED Provision for; Includes Wiring for Body Builder Installation of PTO Controls; with Ignition Switch Control for Cummins ISB/B6.7 or ISL/L9 Engines
13AVR	TRANSMISSION, AUTOMATIC {Allison 3000 RDS} 5th Generation Controls, Close Ratio, 6-Speed with Double Overdrive, with PTO Provision, Less Retarder, Includes Oil Level Sensor, On/Off Highway
13WAW	OIL COOLER, AUTO TRANSMISSION {Modine} Water to Oil Type
13WBL	TRANSMISSION SHIFT CONTROL {Allison} Push-Button Type; for Allison 3000 & 4000 Series Transmission
13WGH	TRANSMISSION DIPSTICK Relocated to Right Side of Transmission
13WLP	TRANSMISSION OIL Synthetic; 29 thru 42 Pints
13WUC	ALLISON SPARE INPUT/OUTPUT for Rugged Duty Series (RDS); General Purpose Trucks, Construction
13WYH	TRANSMISSION TCM LOCATION Located Inside Cab
13WYU	SHIFT CONTROL PARAMETERS Allison 3000 or 4000 Series Transmissions, 5th Generation Controls, Performance Programming
13XAL	PTO LOCATION Left Side of Transmission
14GVU	AXLE, REAR, TANDEM {Meritor MT-40-14X-4DFR-P} Single Reduction, 40,000-lb Capacity, with Lube Oil Pump, w/.433"(11mm) Wall Housing Thickness, R Wheel Ends . Gear Ratio: 6.43 <u>Includes</u> : POWER DIVIDER LOCK Electric over Air Operated, Cab Control with Indicator Light : REAR AXLE DRAIN PLUG (2) Magnetic, For Tandem Rear Axle <u>Notes</u> : The following features should be considered when calculating Rear GAWR: Rear Axles; Rear Suspension; Brake System; Brakes, Rear Air Cam; Brake Shoes, Rear; Special Rating, GAWR; Wheels; Tires.
14UMB	SUSPENSION, REAR, TANDEM {Hendrickson HMX-400-52} Walking Beam Type 52" Axle Spacing; 40,000-lb Capacity, with Rubber End Bushings, Transverse Torque Rods, Less Shock Absorbers <u>Includes</u> : CROSSMEMBER, SUSPENSION Stamped Steel Double Dogbone <u>Notes</u> : The following features should be considered when calculating Rear GAWR: Rear Axles; Rear Suspension; Brake System; Brakes, Rear Air Cam; Brake Shoes, Rear; Special Rating, GAWR; Wheels; Tires.
14WBV	SHOCK ABSORBERS, REAR (4) for Hendrickson HMX Suspension Only, Mounted from Frame to Beam

<u>Code</u>	<u>Description</u>
15LMN	FUEL/WATER SEPARATOR {Racor 400 Series,} 12 VDC Electric Heater, Includes Pre-Heater, with Primer Pump, Includes Water-in-Fuel Sensor
15LMW	LOCATION FUEL/WATER SEPARATOR Mounted Outside Left Rail, 34" Back of Cab
15SGG	FUEL TANK Top Draw, Non-Polished Aluminum, D-Style, 19" Tank Depth, 70 US Gal (265L), with Quick Connect Outlet, Mounted Left Side, Under Cab
15WDG	DEF TANK 7 U.S. Gal. 26.5L Capacity, Frame Mounted Outside Left Rail, Under Cab
16030	CAB Conventional
	<u>Includes</u>
	: ARM REST (2) Molded Plastic; One Each Door
	: COAT HOOK, CAB Located on Rear Wall, Centered Above Rear Window
	: CUP HOLDERS Two Cup Holders, Located in Lower Center of Instrument Panel
	: DOME LIGHT, CAB Rectangular, Door Activated and Push On-Off at Light Lens, Timed Theater Dimming, Integral to Console, Center Mounted
	: GLASS, ALL WINDOWS Tinted
	: GRAB HANDLE, CAB INTERIOR (1) "A" Pillar Mounted, Passenger Side
	: GRAB HANDLE, CAB INTERIOR (2) Front of "B" Pillar Mounted, One Each Side
	: INTERIOR SHEET METAL Upper Door (Above Window Ledge) Painted Exterior Color
	: STEP (4) Two Steps Per Door
16HBA	GAUGE CLUSTER English with English Electronic Speedometer
	<u>Includes</u>
	: GAUGE CLUSTER (6) Engine Oil Pressure (Electronic), Water Temperature (Electronic), Fuel (Electronic), Tachometer (Electronic), Voltmeter, Washer Fluid Level
	: ODOMETER DISPLAY, Miles, Trip Miles, Engine Hours, Trip Hours, Fault Code Readout
	: WARNING SYSTEM Low Fuel, Low Oil Pressure, High Engine Coolant Temp, and Low Battery Voltage (Visual and Audible)
16HGH	GAUGE, OIL TEMP, AUTO TRANS for Allison Transmission
16HHE	GAUGE, AIR CLEANER RESTRICTION {Filter-Minder} with Black Bezel Mounted in Instrument Panel
16HKT	IP CLUSTER DISPLAY On Board Diagnostics Display of Fault Codes in Gauge Cluster
16HLJ	GAUGE, DEF FLUID LEVEL
16JNT	SEAT, DRIVER {National 2000} Air Suspension, High Back with Integral Headrest, Vinyl, Isolator, 1 Chamber Lumbar, with 2 Position Front Cushion Adjust, -3 to +14 Degree Angle Back Adjust
	<u>Includes</u>
	: SEAT BELT 3-Point, Lap and Shoulder Belt Type
16SDU	MIRRORS (2) {Lang Mekra} Styled; Rectangular, Power Both Sides, Thermostatically Controlled Heated Heads, Clearance Lights LED, Bright Finish Heads & Brackets, Breakaway Type, 7.09" x 15.75" & Integral Convex Both Sides, 102" Inside Spacing
16SEE	GRAB HANDLE Chrome; Towel Bar Type with Anti-Slip Rubber Inserts; for Cab Entry Mounted Left Side Only at "B" Pillar
16SMN	SEAT, PASSENGER {National} Non Suspension, High Back, Fixed Back, Integral Headrest, Vinyl
16WBY	ARM REST, RIGHT, DRIVER SEAT
16WCT	AIR CONDITIONER {Blend-Air} with Integral Heater & Defroster
	<u>Includes</u>
	: HEATER HOSES Premium
	: HOSE CLAMPS, HEATER HOSE Mubea Constant Tension Clamps
	: REFRIGERANT Hydrofluorocarbon HFC-134A

<u>Code</u>	<u>Description</u>
16WJS	INSTRUMENT PANEL Center Section, Flat Panel
16WJU	WINDOW, POWER (2) and Power Door Locks, Left and Right Doors, Includes Express Down Feature
16WKY	HVAC FRESH AIR FILTER
16WLE	STORAGE POCKET, DOOR Molded Plastic, Full Width; Mounted on Passenger Door
16WRX	CAB INTERIOR TRIM Deluxe
	<u>Includes</u>
	: CAB INTERIOR TRIM PANELS Cloth Covered Molded Plastic, Full Height; All Exposed Interior Sheet Metal is Covered Except for the Following: with a Two-Man Passenger Seat or with a Full Bench Seat the Back Panel is Completely Void of Covering
	: CONSOLE, OVERHEAD Molded Plastic; With Dual Storage Pockets with Retainer Nets and CB Radio Pocket
	: DOOR TRIM PANELS Molded Plastic; Driver and Passenger Doors
	: FLOOR COVERING Rubber, Black
	: HEADLINER Soft Padded Cloth
	: INSTRUMENT PANEL TRIM Molded Plastic with Black Center Section
	: STORAGE POCKET, DOOR (1) Molded Plastic, Full-Length; Driver Door
	: SUN VISOR (2) Padded Vinyl; 2 Moveable (Front-to-Side) Primary Visors, Driver Side with Toll Ticket Strap
16WSK	CAB REAR SUSPENSION Air Bag Type
16XWJ	WINDSHIELD WIPER BLADES Snow Type
27DPN	WHEELS, FRONT {Accuride 29039} DISC; 22.5x9.00 Rims, Powder Coat Steel, 5-Hand Hole, 10-Stud, 285.75mm BC, Hub-Piloted, Flanged Nut, with Steel Hubs, Non-Standard Offset, with .5" Thick Disc
28DTC	WHEELS, REAR {Maxion 90541} DUAL DISC; 22.5x8.25 Rims, Painted Steel, 2-Hand Hole, 10-Stud, 285.75mm BC, Hub-Piloted, Flanged Nut, with Aluminum Hubs
29PAS	PAINT IDENTITY, REAR WHEELS Disc Rear Wheels; with Vendor Applied White Powder Coat Paint
29WAR	WHEEL GUARDS, REAR {Accuride} for Metric Hub Piloted Wheels with Flanged Mounting Nuts, Mounted Between Hub & Wheel and Between Dual Wheels
60AAG	BDY INTG, REMOTE POWER MODULE Mounted Inside Cab behind Driver Seat; Up to 6 Outputs & 6 Inputs, Max. 20 amp. per Channel, Max. 80 amp Total (Includes 1 Switch Pack with Latched Switches)
7372138102	(8) TIRE, REAR 11R22.5 Load Range G G622 RSD (GOODYEAR), 497 rev/mile, 75 MPH, Drive
7772548123	(2) TIRE, FRONT 315/80R22.5 Load Range L G751 MSA (GOODYEAR), 484 rev/mile, 68 MPH, All-Position
	Services Section:
40115	WARRANTY Standard for WorkStar 7300/7400 (4x2, 4x4, 6x4, 6x6), Effective with Vehicles Built January 2, 2015 or Later, CTS-2002U
	Dump Body and Snow Plow Equipment (Kankakee Truck Equipment)

<u>Description</u>	<u>(US DOLLAR)</u>	<u>Price</u>
Factory List Prices:		
Product Items	\$139,361.00	
Service Items	\$0.00	
Total Factory List Price Including Options:		\$139,361.00
Total Goods Purchased:		\$63,402.00
Pak	\$1,650.00	
Total Preparation And Delivery:		\$1,650.00
Freight	\$2,325.00	
Total Freight:		\$2,325.00
Total Factory List Price Including Freight:		\$206,738.00
Less Customer Allowance:		(\$50,434.00)
Total Vehicle Price:		\$156,304.00
Total Sale Price:		\$156,304.00
Total Per Vehicle Sales Price:		\$156,304.00
Total Net Sales Excluding Taxes:		\$156,304.00
License and Title	\$103.00	
Doc Fee	\$164.00	
Total License, Title, & Taxes:		\$267.00
Net Sales Price:		\$156,571.00

Please feel free to contact me regarding these specifications should your interests or needs change. I am confident you will be pleased with the quality and service of an International vehicle.

Approved by Seller:

Accepted by Purchaser:

Official Title and Date

Firm or Business Name

Authorized Signature

Authorized Signature and Date

This proposal is not binding upon the seller without Seller's Authorized Signature

Official Title and Date

The TOPS FET calculation is an estimate for reference purposes only. The seller or retailer is responsible for calculating and reporting/paying appropriate FET to the IRS.

Kankakee Truck Equipment, Inc.
785 Eastgate Industrial Parkway
Kankakee, IL 60901
Phone: 815-939-2541 Fax: 815-939-1701
7/16/2018

City of Wilmington Public Works Department
1165 S Water Street
Wilmington, IL 60481

Attn. Mr. Fowler :

We are pleased to make the following reference: City of Wilmington

- Galion Model 533FT-13
- 7 ga. 201 bright finish SS sides and ends
- 3/16 AR 450 floor
- 36'' sides 44'' tail gate
- Mailhot SA telescopic hoist
- Folding ladder
- Rear flaps and front SS fenders
- Air tail gate
- Tarp rail
- Whelen Light system
- Cab mounted light bar
- Rear Amber/ white flashing lights and LED BT/T in corner post
- Brake /tail and amber flashing light in top rear of cab shield
- LED lights on light bar, Front mount plow lights
- 1 rear facing spreader light
- Open loop hydraulic system
- RVC cable controls for plow and dump
- Hot shift PTO and direct mount pump
- Carbon steel valve /tank
- Force model 3100 Electric spreader control
- Lines run to rear for spreader
- BSI custom side plated hitch
- Flink push frame with QL2
- Flink TTPA trip cutting plow
- 11' straight moldboard with rubber deflector
- ¾ 20 ton pintle hitch
- VCT12 304 SS construction
- 6'' direct drive auger

- 18'' self leveling poly spinner
- All above equipment mounted and painted

Total price for one complete unit :\$ 63,402.00 (included in
\$ 156,571.⁰⁰)

We thank you for the opportunity to be of service. If there are any questions regarding this Proposal or to place an order for any equipment described, please contact us at your convenience.

Sincerely,

Dean Kleinert
President

Order by phone 1-800-210-2370



Locations
My Account
Alerts
My Cart

All Departments ▾

Current Ad

How To ▾

Gifts ▾

Store Locator ▾

Today's Deals

[Home](#) > [Farm and Livestock](#) > [Farm Equipment](#) > [3 Point Equipment](#)

Farm-N-Fleet

King Kutter Gear Driven Rotary Tiller

Blain # 288143 | Mfr # TG-72-YK

★★★★★ 5.0 (4) [Write a review](#)



Today's Price

\$1,939.99

Width: 72"

48" 60" 72" 84"

Quantity:

Share This



Ship This Item ✔ In Stock

Usually ships within 24 hours

NOTE: Large item requires delivery appointment and may require a lift gate fee.

Free In-Store Pickup ✔ 2 left at Bourbonnais

[Hours / Map](#) | [Change Local Store](#)

Add To Cart

About This Item ▾

Product Q & A ▾

Product Reviews ▾

Back To Top ▲



ITEM DESCRIPTION	EACH	QTY	TOTAL
Construction Attachments General Purpose High Capacity Light Material Skid Steer Bucket (ProductDetails.asp?ProductCode=CAL%2DBucket%2DGP%2D1GPHCLM&CartID=1) [+] View list of options I selected	\$1,610.00	1	\$1,610.00

(ShoppingCart.asp?remove=1)

Click to remove an item from your cart [Empty My Entire Cart](#) (ShoppingCart.asp?ClearCart=Y)

Coupon code? Enter it here:

Show gift options during checkout

Tax: \$0.00
Total: \$1,610.00

[Proceed To Checkout](#)

[View Cart \(/shoppingcart.asp\)](/shoppingcart.asp)

[About Us \(/aboutus.asp\)](/aboutus.asp)

[Contact Us \(/category-s/3784.htm\)](/category-s/3784.htm)

[EA Warranty \(https://www.everythingattachments.com/Articles.asp?ID=279\)](https://www.everythingattachments.com/Articles.asp?ID=279)

[Company Info \(https://www.everythingattachments.com/aboutus.asp\)](https://www.everythingattachments.com/aboutus.asp) |
 [Privacy Policy \(/terms_privacy.asp\)](/terms_privacy.asp) |
 [Advertising \(https://www.everythingattachments.com/articles.asp?ID=7\)](https://www.everythingattachments.com/articles.asp?ID=7) |
 [Product Index \(https://www.everythingattachments.com/pindex.asp\)](https://www.everythingattachments.com/pindex.asp) |
 [Category Index \(https://www.everythingattachments.com/cindex.asp\)](https://www.everythingattachments.com/cindex.asp) |
 [Help \(https://www.everythingattachments.com/help.asp\)](https://www.everythingattachments.com/help.asp) |
 [Terms of Use \(https://www.everythingattachments.com/terms.asp\)](https://www.everythingattachments.com/terms.asp) |
 [EA Warranty \(https://www.everythingattachments.com/Articles.asp?ID=279\)](https://www.everythingattachments.com/Articles.asp?ID=279) |
 [Send Us Feedback \(mailto:sales@everythingattachments.com?subject=Customer Feedback for www.everythingattachments.com\)](mailto:sales@everythingattachments.com?subject=Customer%20Feedback%20for%20www.everythingattachments.com) |
 [My Account \(http://www.everythingattachments.com/myaccount.asp\)](http://www.everythingattachments.com/myaccount.asp)

Everything Attachments: 1(866) 581-5818 (tel:+18665815818), 12 South Ashe Ave Newton NC 28658
 Copyright © 2018 www.everythingattachments.com. All Rights Reserved. (/terms.asp) Built with Volusion.
 Skid Steer Attachments, Tractor Implements, Excavator Attachments for Sale - Order Online

Select Language Powered by [Google Translate \(https://translate.google.com\)](https://translate.google.com)

Bush Hog® BH 20 Single-Spindle Rotary Cutters

BH20 Series (BH25, **BH26**, & BH27 Models)

Bush Hog's Famous Reliability In A Medium-Duty Cutter

Bush Hog®'s BH20 Series Rotary Cutters bring our famous reliability to brush cutting and weed and grass mowing for farms, estates, and highway right-of-way mowing. Built with Bush Hog®'s tough features, this series delivers superior performance the first day on the job and for years to come.

Place your mouse over the image to enlarge any portion of the product below.

Sister

\$4500

5 yr Warranty on GEAR
BOX

DF 8-17-2018



NOTE: Unit(s) shown equipped with certain selections and options; please consult with your local Bush Hog dealer for all available configurations.

Features

Performance Features

Below Deck Structure of strongbacks and gearbox stand allows for a smooth top deck which sheds water and debris.
Continuously welded Side Bands tied together through the integrated gearbox stand.
Replaceable Full Length 1/4-Inch Skids run one-half the length of the deck to protect side bands and add strength that resists bending.
Floating Hitch for unlevel terrain
5-Year Gearbox Limited Warranty
Powder Coat Paint
Durable Tailwheel Beam

Construction Features

EZ Clean Sloped 10-Gauge Decks —eliminate trash build up and water traps.
Bush Hog® Gearboxes has splined output shafts with tapered roller bearings resist thrust and side loads as the pan pushes the cutter up or to the side of large obstacles like rocks or stumps.
Powder Coat Paint in colors that match today's tractors is baked on to resist rust and nicks through years of rugged work.
Tail Wheel Beam has 3/16-inch wall and is clamped between two heavy steel plates for a secure fit to resist side loads during turns. Dual tail wheels available on BH27.
5-Year Gearbox Limited Warranty comes with each new BH20 Series Cutter.
1/4-inch continuously welded sidebands formed of 1/4-inch thick steel and 12 1/2-inches deep for large volumes of material.
130 HP Bush Hog® Gearbox

Product Features



Adjustable Slip Clutches are standard equipment.

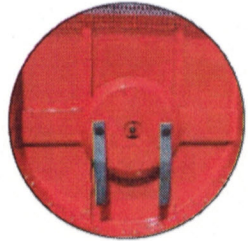

Decks are reinforced with internal 7-gauge steel strongbacks that run the full length of the deck, tying together the entire structure with the gearbox stand. Bush Hog® blade pans are round to allow the mower to float over field obstructions.

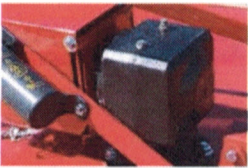

Quick Detach Gearbox Shield



Floating Hitch for unlevel terrain

Specifications

Model	BH25	BH26	BH27
Cutting Width	5-feet	6-feet	7-feet
Cutting Capacity	3-inch diameter	3-inch diameter	3-inch diameter
Cutting Height	1 1/2 to 10 1/2-inches	1 1/2 to 10 1/2-inches	1 1/2 to 10 1/2-inches
Dimensions (transport width x length)	5-feet 6-inches x 8-feet 8-inches	6-feet 6-inches x 9-feet 8-inches	7-feet 6-inches x 10-feet 8-inches (single wheels) 10-feet 1-inch (double wheels)
Type Hitch	3 Point Cat. I, Cat. II Standard & QH	3 Point Cat. I, Cat. II Standard & QH	3 point, cat II & III, standard and QH.
Deck Thickness	10-gauge	10-gauge	10-gauge
Sidebands	1/4 x 12 1/2-inches	1/4 x 12 1/2-inches	1/4 x 12 1/2-inches
Driveshaft	ASAE Category 4	ASAE Category 4	ASAE Category 4
Gearbox	130 HP	130 HP	130 HP
Tractor PTO Speed	540 RPM	540 RPM	540 RPM
Driveline Protection	Slip Clutch Standard	Slip Clutch Standard	Slip Clutch Standard
Blade Holder(s)	Round	Round	Round
Blades	1/2 x 4-inch uplift	1/2 x 4-inch uplift	1/2 x 4-inch uplift
Blade Tip Speed	14,600 FPM	15,000FPM	14,450 FPM
Tires	Single Laminated	Single Laminated	Single or Double Laminated
Minimum Tractor HP	35 PTO	45 PTO	55 PTO
Safety Shielding	Front and Rear Deflectors or Front and Rear Chains	Front and Rear Chains	
Approximate Weight	906-lbs.	1095-lbs.	1328-lbs.
Warranty	1 year limited warranty with a 5 year gearbox limited warranty		
FEATURES	Available in major tractor colors		

Warning: For non-agricultural use, OSHA, ASAE, SAE, and ANSI standards require the use of chain guards or other protective guards at all times. Bush Hog® strongly recommends the use of such guards for agricultural uses as well, to reduce the risk of property damage, serious bodily injury or even death from objects thrown out by or from contact with the cutting blades.

Kankakee Truck Equipment, Inc.
785 Eastgate Industrial Parkway
Kankakee, IL 60901
Phone: 815-939-2541 Fax: 815-939-1701
8/17/2018

City of Wilmington
114 N. Main
Wilmington, IL 60481

Attn. Mr. Fowler :

We are pleased to make the following reference: Trailer

- 1998 Eager Beaver trailer
- 20 ton cap.
- 20' flatbed 60 beaver tail
- 48" folding ramps
- Current safety sticker
- Your pickup

Total price for one complete unit : \$ 3,700.00

We thank you for the opportunity to be of service. If there are any questions regarding this Proposal or to place an order for any equipment described, please contact us at your convenience.

Sincerely,

Dean Kleinert
President

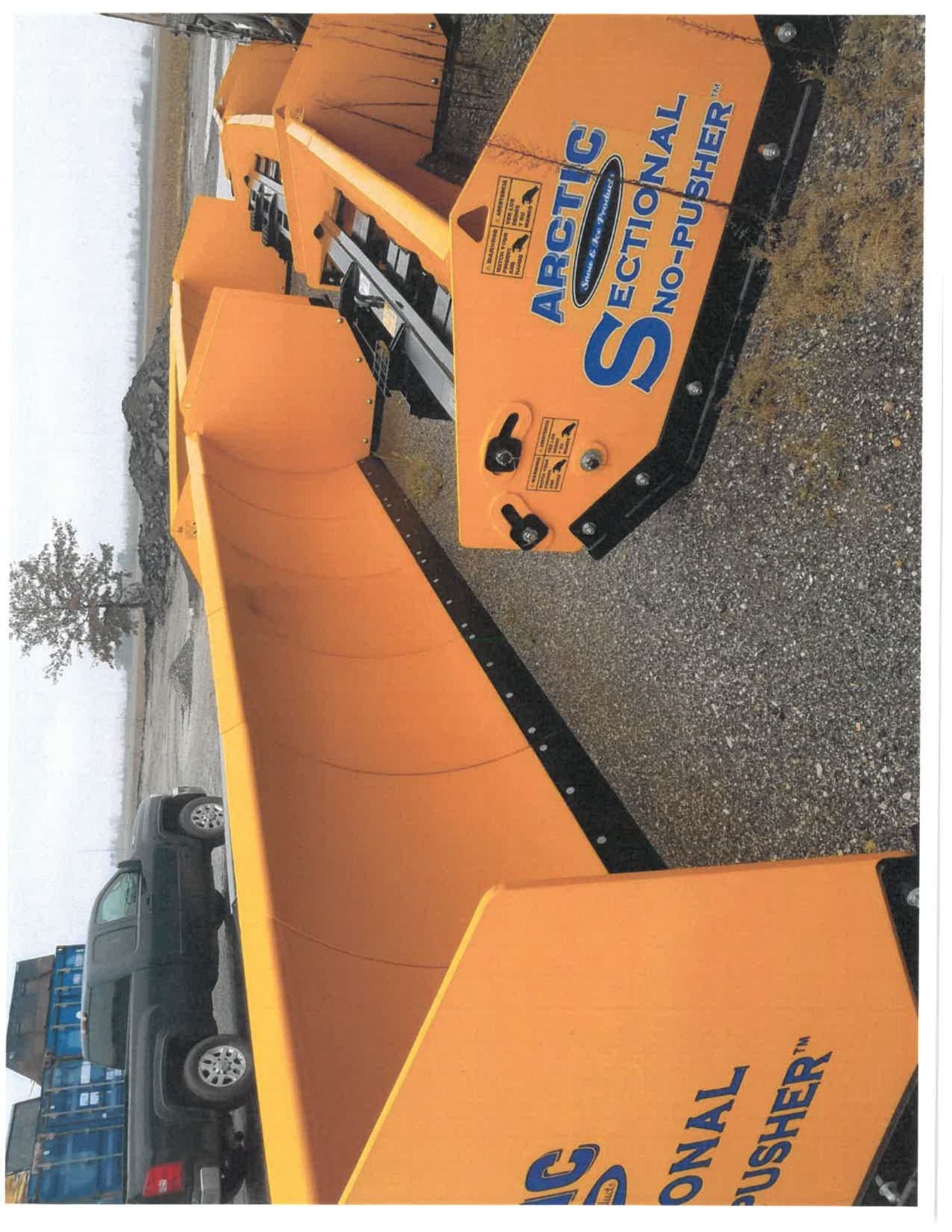

ARCTIC
SECTIONAL
NO-PUSHER™

WARNING: READ AND UNDERSTAND ALL INSTRUCTIONS BEFORE OPERATING. ALWAYS WEAR YOUR SAFETY BELT AND SEATBELT. ALWAYS WEAR YOUR SAFETY GLASSES. ALWAYS WEAR YOUR SAFETY SHOES. ALWAYS WEAR YOUR SAFETY GLOVES.

WARNING: READ AND UNDERSTAND ALL INSTRUCTIONS BEFORE OPERATING. ALWAYS WEAR YOUR SAFETY BELT AND SEATBELT. ALWAYS WEAR YOUR SAFETY GLASSES. ALWAYS WEAR YOUR SAFETY SHOES. ALWAYS WEAR YOUR SAFETY GLOVES.

ARCTIC
SECTIONAL
NO-PUSHER™